



ULTRACARE

At the Cutting Edge of Industry

NH

UNIVERSAL CUTTER GRINDER

INSTRUCTION MANUAL No.770

UNIVERSAL CUTTER GRINDER

Model NH

Wadkin UltraCare Limited

Tel: service +44 (0) 870 850 9112

: tooling +44 (0) 870 850 9113

: spares +44 (0) 870 850 9114

Fax: +44 (0) 870 2400 575

E-mail: info@wadkinultracare.com

Web: www.wadkinultracare.com

Wadkin

Universal Cutter Grinder, Type N.H.

PRINCIPAL DIMENSIONS AND CAPACITIES

Maximum length of knife ground, 12" machine	12 $\frac{1}{2}$ "
Maximum length of knife ground, 24" machine, using dividing head	12 $\frac{1}{2}$ "
Maximum length of knife ground, 24" machine, using dummy block attachment	24 $\frac{1}{2}$ "
Longitudinal travel of table, 12" machine	16"
Longitudinal travel of table, 24" machine	28"
Cross travel of table	9 $\frac{1}{4}$ "
Minimum height of centre of grinding wheel to table	6 $\frac{3}{4}$ "
Maximum height of centre of grinding wheel to table	15 $\frac{1}{2}$ "
Wheelhead swivels	240°
Diameter of grinding wheels	6" or 7"
Speed of grinding wheel spindle	2800 r.p.m.
Horse power of standard motor	2
Speed of motor	2800 r.p.m.
Floor space with maximum movements, 12" machine	5' 4" x 4' 3"
Floor space with maximum movements, 24" machine	7' 10" x 4' 3"
Nett weight in cwts., 12" machine	16 cwts.
Nett weight in cwts., 24" machine	17 cwts.

DETAILS INCLUDED WITH THE MACHINE

6" dia. taper cup grinding wheel ; 7" dia. dish grinding wheel ; one wheel mounting sleeve ; set of spanners ; grease gun.

INSTALLATION

The machine is despatched from the works with all bright surfaces greased to prevent rusting. This must be removed by applying a cloth damped in paraffin.

FOUNDATIONS

If mill floor consists of concrete no special foundation is necessary. Half-inch diameter rag bolts or plates and bolts should be used (not supplied with machine). Cut 4" square holes in concrete and run with liquid cement to fix. Alternatively "Rawlplugs" may be used. A good wood floor is satisfactory and coachscrews may then be used. The machine should be carefully levelled before fixing and again after final fixing to ensure that no distortion has taken place.

An eyebolt for lifting is fitted to the machine. When this is removed, plug the hole to prevent entrance of dust and grit to internal mechanism.

WIRING

See wiring diagram, page 3, for full installation instructions.

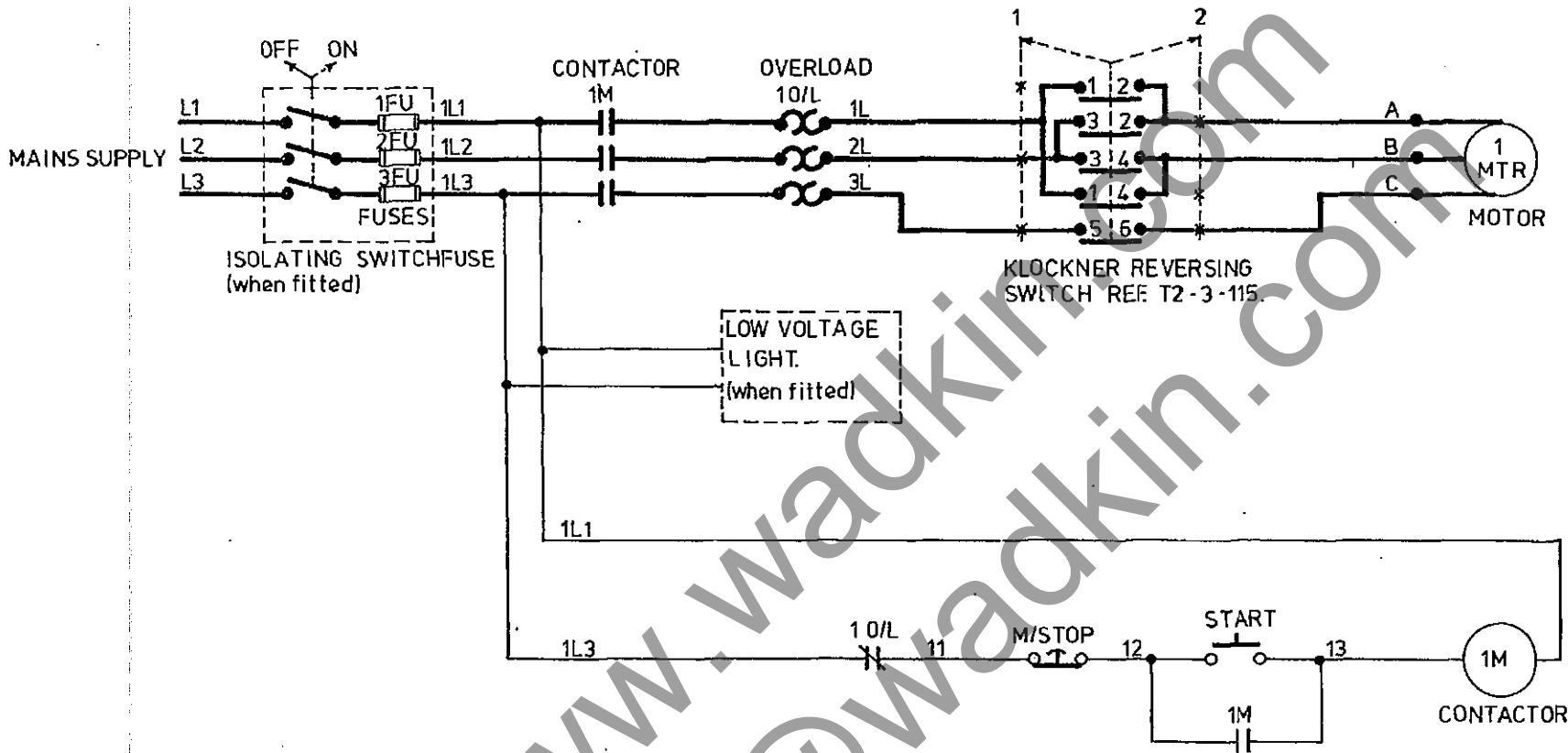

PART No.

SIMILAR TO

WADKIN LTD. LEICESTER

DATE
31.1.78

A

DESCRIPTION
SINGLE MOTOR CONTROL.
DIRECT-ON-LINE STARTING
WITH REVERSE.

QTY. MATERIAL

DRN. BY *gml*

CHKD. BY

PART No.

D.2545

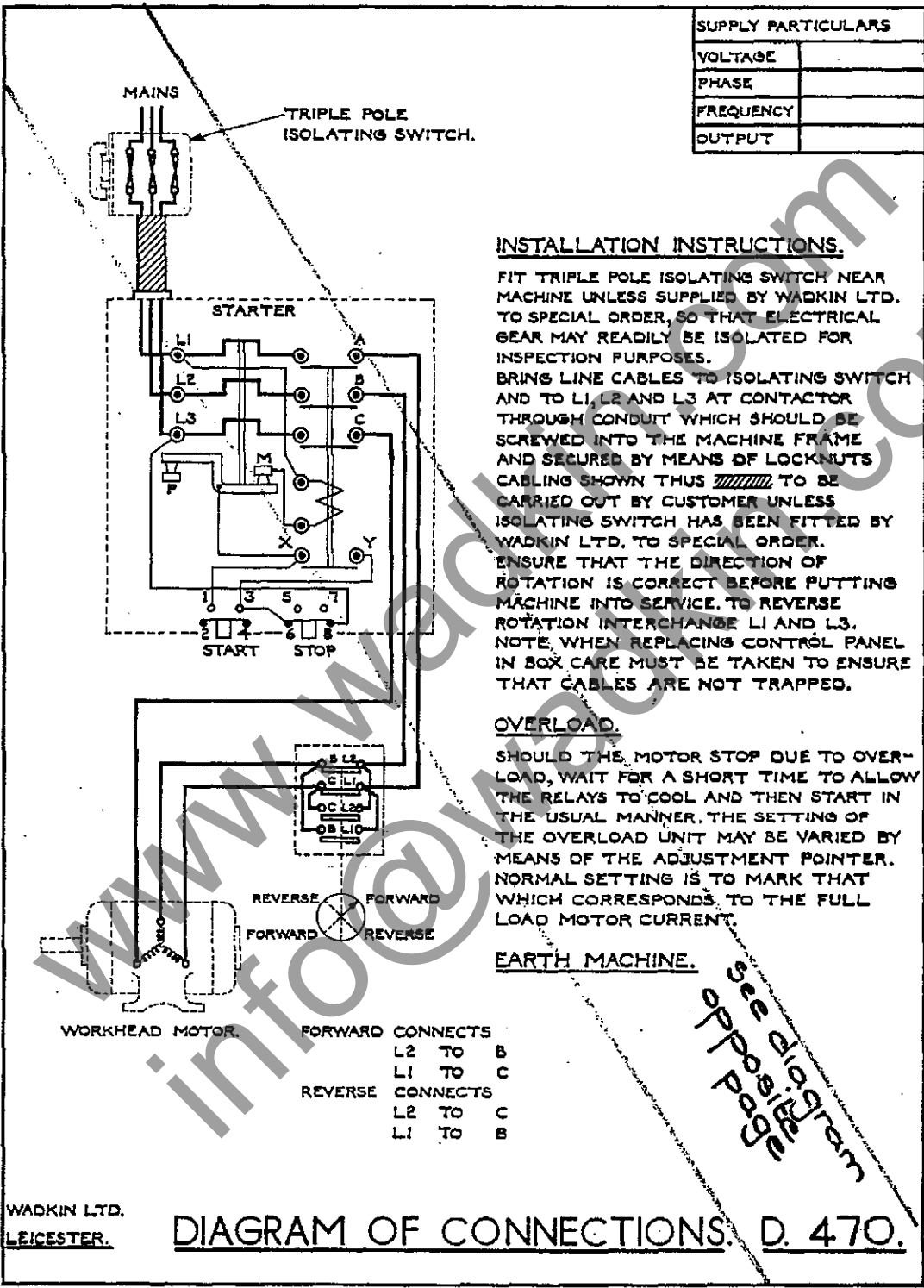

- FORWARD CONNECTS**
L2 TO B
L1 TO C
- REVERSE CONNECTS**
L2 TO C
L1 TO B

GENERAL DESCRIPTION OF MACHINE

The machine has been designed for grinding many types of cutter equipment, using the various fixtures which are available.

The table has longitudinal movement on hardened and precision ground profile ball bearing rollers engaging two nitralloy rods on the underside of the table. The longitudinal control is by handwheel operating a precision cut steel pinion and rack. Cross traverse motion is by fine pitch screw, being fitted with dials graduated in $.001''$ or $.1$ mm. for giving a fine feed. The longitudinal travel, cross adjustment and raise and lowering movements are operated by handwheels at the front of the machine and duplicated at the rear to facilitate setting up.

The table has a tee slot machined in the top to carry the fixtures required for the different classes of work. It is also slotted on the front edge to carry adjustable stops controlling the limit of table travel.

The grinding wheel head is arranged to swivel on a circular base plate. The movement is through 240° to allow either wheel to be presented over the table and in addition swivelled up to 30° right or left for hollow grinding. The head embodies a 2 h.p. squirrel cage motor mounted directly on to the spindle. Precision pre-loaded ball bearings are fitted. The spindle is arranged to take either 6" diameter taper cup wheels, 7" diameter dish wheels or diamond impregnated wheels. The rise and fall movement to the head is operated by screw and spiral gears working in a totally enclosed box inside the main frame. The vertical slide is totally enclosed in a collapsible bellows as a protection against dust and grit. The head motor is controlled by a direct on contactor starter with no-volt and three overload releases operated by start and stop push buttons. A reversing switch is provided so that the wheels can be run in either direction.

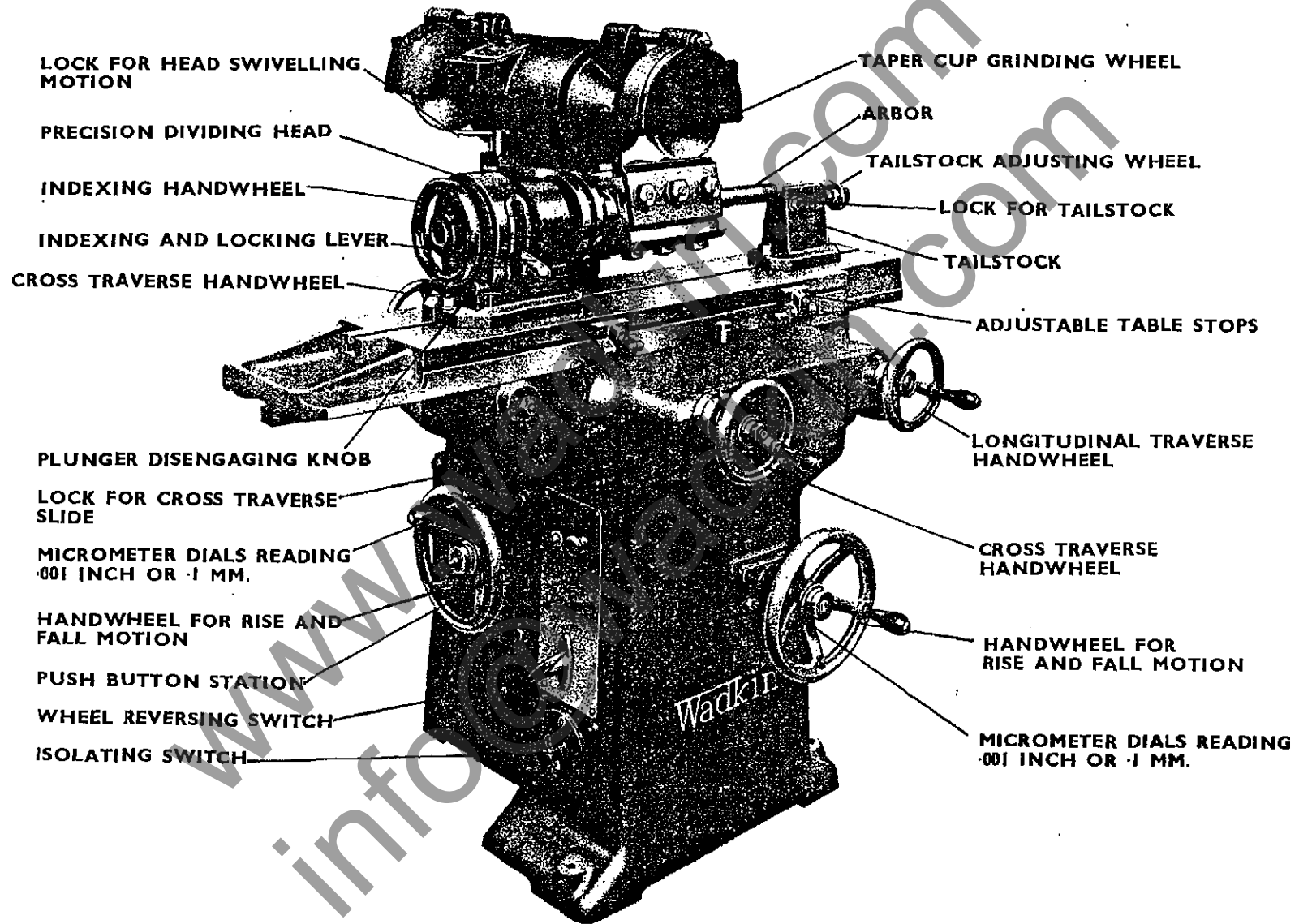

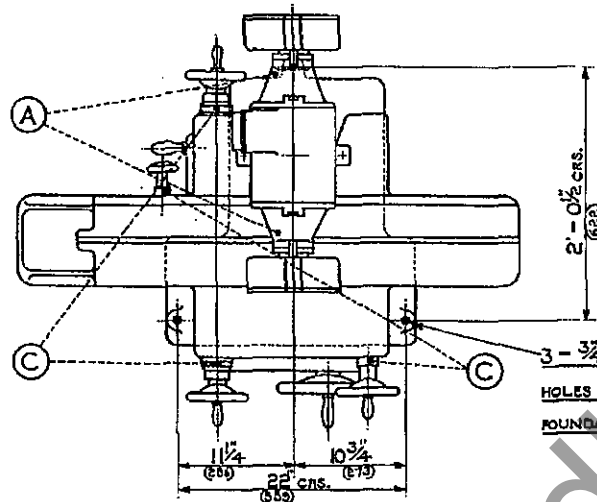

3 - 3/4 (95) DIA. CORED HOLES FOR 1/2 (35) DIA. FOUNDATION BOLTS.

FOUNDATION PLAN AND LUBRICATION CHART FOR UNIVERSAL CUTTER GRINDER. TYPE NH.

DIMENSIONS IN FEET, INCHES AND M.M.

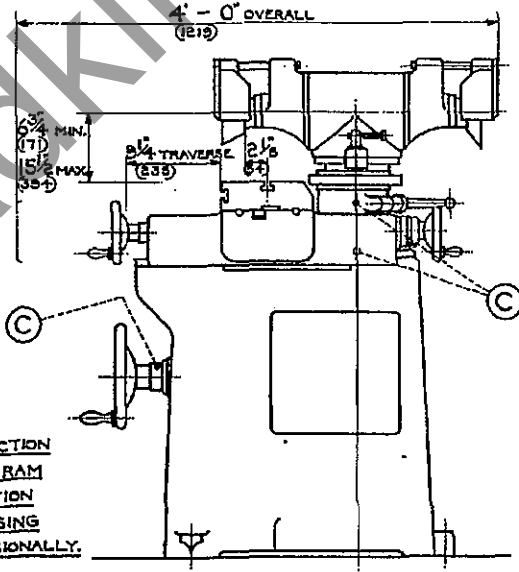
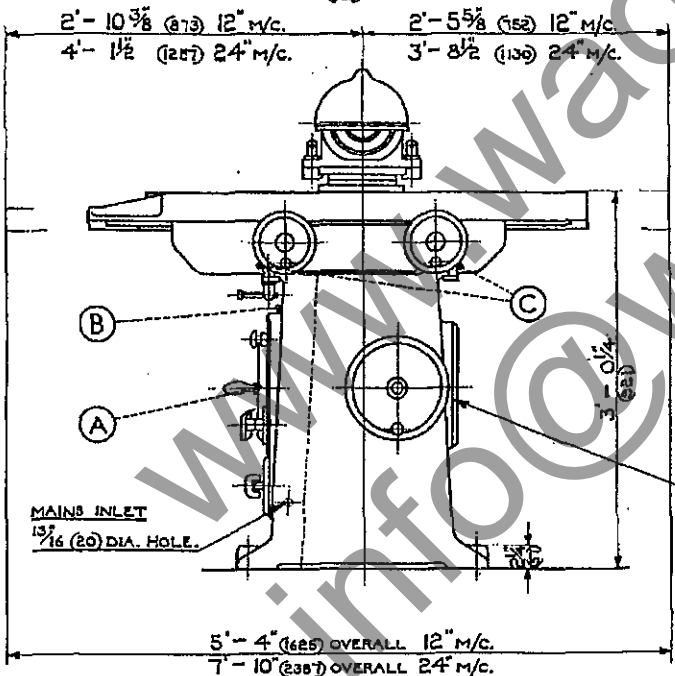

REMOVE INSPECTION COVER, RAISE RAM TO TOP POSITION AND OIL RAISING SCREW OCCASIONALLY.

LUBRICATION

POINTS A. Give four to six depressions of grease gun every four to six months, using Wadkin Ball Bearing Grease, Grade L6.

POINTS B. Give one or two depressions of grease gun every two months, using Wadkin Ball Bearing Grease, Grade L6.

POINTS C. Oil once per week, using Wadkin oil, Grade L4.

NOTE. The table rollers are packed with grease on assembly, and no further lubrication is necessary.

If it is desired to use lubricants other than Wadkin, the equivalents are listed below:—

WADKIN BALL BEARING GREASE, L6 Equivalent : Shell Mex & B.P. Ltd. "Nerita" Grease 3.
 Vacuum Oil Co. "Gargoyle", BRB3 Grease.
 Caltex Lubricants. Regal Starfak No. 2 Grease.

WADKIN OIL, GRADE L4 Equivalent : Shell Mex & B.P. Ltd. "Vitrea" Oil 33.
 Vacuum Oil Co. "Vactra" Oil (heavy medium).
 Caltex Lubricants. Caltex Aleph Oil.

BEARING LIST

Spindle bearings	2 per machine	.. Hoffman Reference N4825. 1 $\frac{1}{8}$ " bore \times 2 $\frac{1}{2}$ " O/D \times $\frac{5}{8}$ " wide.
Spindle bearing	1 per machine	.. Ransome & Marles LRJ 1 $\frac{1}{8}$ " Single Row Roller Journal. 1 $\frac{1}{8}$ " bore \times 2 $\frac{1}{2}$ " O/D \times $\frac{5}{8}$ " wide.
Elevating Screw Thrust Bearing	1 per machine	.. SKF O8 1" bore \times 1 $\frac{3}{4}$ " O/D \times $\frac{5}{8}$ " wide.
Table roller	4 per machine	.. FG1035.

NOTE.—Replacement bearings for the Hoffman N4825 and FG1035 must be obtained from Wadkin Ltd., as these are specially manufactured for Wadkin Ltd.

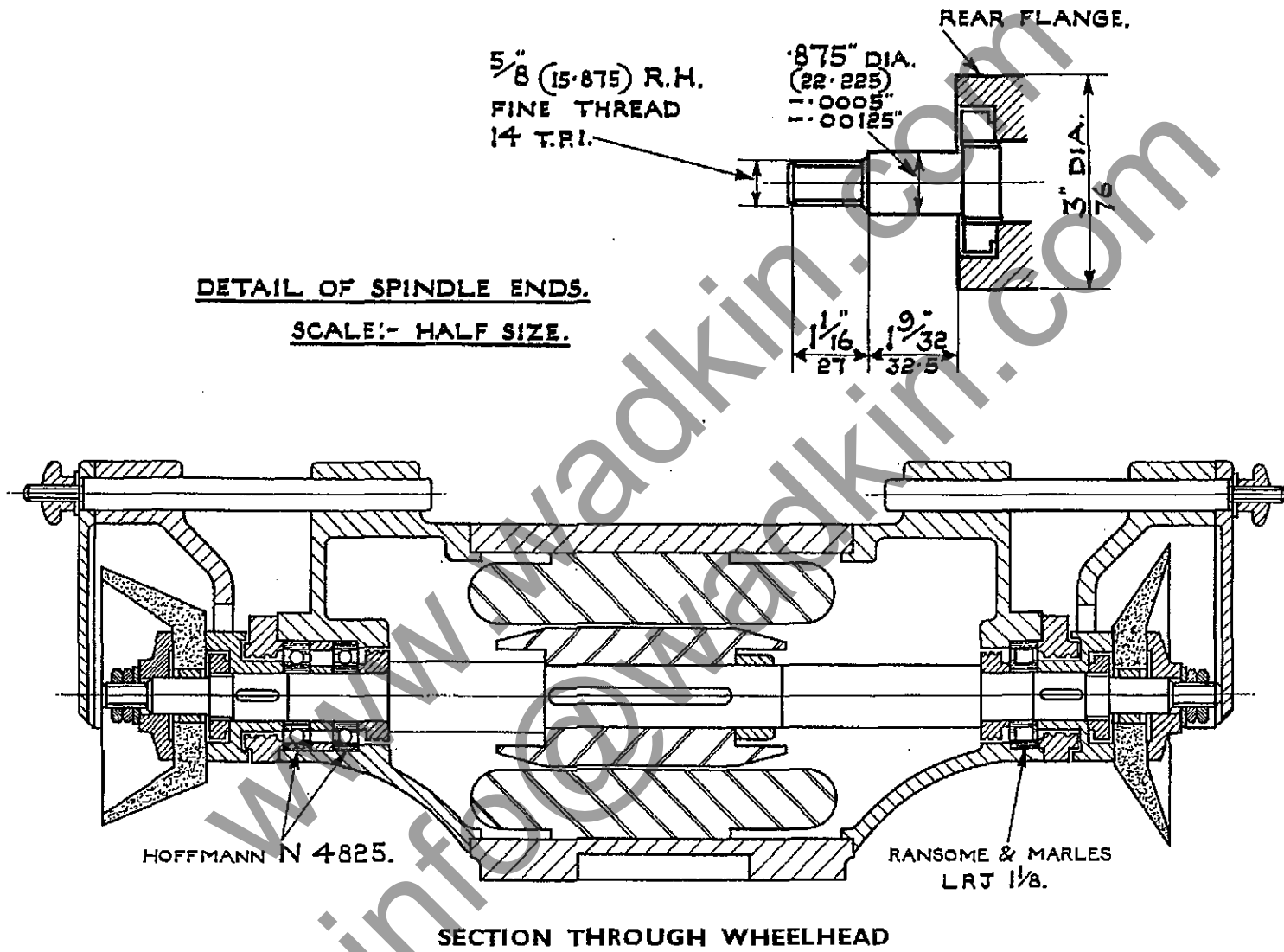

GRINDING WHEELS

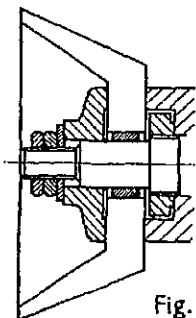

Fig. 1.

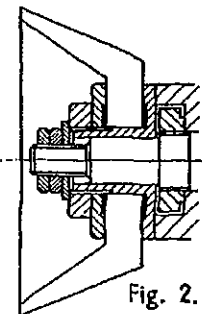

Fig. 2.

The normal method of wheel mounting is by means of a loose bush as Fig. 1. We strongly recommend however on grounds of economy and accuracy that a screwed sleeve bush is used as Fig. 2. Once mounted on the sleeve and the wheel accurately dressed on the spindle, it can be removed and replaced on the spindle repeatedly without the need for retrueing.

One screwed sleeve for use with any of the standard wheels is supplied with the machine, complete with two special peg wrenches for locking up.

ELECTRIC SUPPLY
50 cycles 60 cycles.

The following grinding wheels are supplied with the machine:—

6" Taper Cup Wheel.	2 $\frac{3}{8}$ " wide.	Type 130/A.	164.	For all high speed steel, thick or thin knives, matcher heads, P.M. heads.
7" Dish Wheel.	1 $\frac{1}{4}$ " wide.	Type 131/A.	165.	For solid profile type heads in alloy and high speed steel.

The following grinding wheels can be supplied to special order:—

6" Taper Cup Wheel.	2 $\frac{3}{8}$ " wide.	Type 160.	160.	For rough grinding tungsten carbide tipped knives.
6" Taper Cup Wheel.	2 $\frac{3}{8}$ " wide.	Type 159.	159.	For finish grinding tungsten carbide tipped knives.
7" Dish Wheel.	1 $\frac{1}{4}$ " wide.	Type 162.	168.	For rough grinding tungsten carbide tipped solid profile type heads.
7" Dish Wheel.	1 $\frac{1}{4}$ " wide.	Type 161.	169.	For finish grinding tungsten carbide tipped solid profile type heads.
6" Diamond Lapping Wheel.	$\frac{3}{4}$ " wide.	Type 163.	163.	For sharpening tungsten carbide tipped saws and cutters.
6" Dish Wheel.	1 $\frac{1}{4}$ " wide.	Type 168.	168.	For rough grinding tungsten carbide tipped saws.
6" Dish Wheel.	1 $\frac{1}{4}$ " wide.	Type 169.	169.	For finish grinding tungsten carbide tipped saws.
6" Cup Wheel.	2" wide.	Type 170.	170.	For grinding drills in conjunction with drill grinding attachment.

NOTE.—All the above wheels (except the diamond wheel) are lead bushed.

GRINDING WHEELS FOR ROUTER CUTTER GRINDING ATTACHMENTS.

4" Cup Wheel	2" wide	Type 177	For high speed steel router cutters
4" Taper Cup Wheel	2" wide	Type 178	For high speed steel router cutters
4" Square Edge Wheel	$\frac{3}{8}$ " wide	Type 179	For high speed steel router cutters
4" Round Edge Wheel	$\frac{1}{4}$ " wide	Type 180	For high speed steel router cutters
4" Round Edge Wheel	$\frac{3}{16}$ " wide	Type 181	For high speed steel router cutters
4" Diamond Lapping Wheel	$1\frac{1}{2}$ " wide	Type 182	For sharpening tungsten carbide tipped cutters
4" Taper Cup Wheel	2" wide	Type 183	For rough grinding tungsten carbide tipped cutters
4" Taper Cup Wheel	2" wide	Type 184	For finish grinding tungsten carbide tipped cutters

NOTE — All the above wheels (except the diamond wheel) are lead bushed.

When router cutter grinding attachments are ordered, a full range of grinding wheels for use with the attachments is supplied.

WADKIN-REVLAC PRECISION DIVIDING HEAD

The dividing head is specially made to suit the requirements for woodworking tool and cutter grinding, by C. M. G. Calver Ltd., Bushey, Herts., and includes their patented features. It is arranged for working 2, 3, 4, 6 or 8 tooth cutters up to 10" diameter. A feature of the head is that a masking plate is built into it, and by positioning a stop screw, the choice of 2, 3, 4, 6 or 8 divisions can be obtained so that the operator cannot accidentally drop into the wrong division, e.g., when grinding a two tooth cutter, all slots in the dividing plate are masked except two opposite ones and this prevents the operator indexing incorrectly and gashing the block or cutter body. The indexing lever also operates as a positive screw lock, when used in the opposite direction, for the spindle of the dividing head.

To select the index required, unscrew the screw provided on the plate nearest the indexing handwheel and move the hole over which is stamped the required number to the position vacated when the screw is removed ; re-insert the screw and lock. The required index is now ready for use.

WADKIN-REVLAC PRECISION DIVIDING HEAD *(Continued)*

To operate the dividing head, press the indexing lever down to its extreme position. This releases the plunger from the indexing plate. While the lever is held down, the indexing handwheel may be turned. The lever is then allowed to return a few degrees under the pressure of the plunger spring, and as the handwheel is turned to the next working position the locating plunger engages the next unmasked position in the indexing plate. By pressing the lever upwards, the assembly is securely locked in position.

Provisions are made on the dividing head which will enable the operator to cut out the indexing mechanism. A small plunger is situated below the indexing handwheel. When this plunger is revolved at a point when the indexing lever is pushed down to its maximum position, it will engage into the plunger actuating arm and retain the plunger in an "out-of-position" condition, thus enabling the whole spindle to be rotated freely by the use of the indexing handwheel. The spindle can be locked in any position, free of the indexing mechanism, by pressing the indexing lever upwards.

To re-engage the indexing mechanism, press the indexing lever down and turn and release the small plunger. Turn the indexing handwheel until the indexing plunger engages in the indexing plate.

LUBRICATION AND MAINTENANCE

Every reasonable precaution has been taken to ensure that this head will give maximum life and efficiency. Precautions have been taken to prevent as much foreign matter from reaching vital indexing parts and under normal conditions of usage it is not anticipated that much interference of correct indexing movement is likely. To maintain correct indexing, absolute cleanliness of operation is essential. One further point to be considered is that the fits and limits relating to the moving parts are such as to make allowances for a thin film of oil to ensure free movement of revolving or sliding parts, and on several points on the dividing head will be found oilers which will carry the oil to these moving parts, and in order to maintain good running conditions it is necessary to oil these points frequently.

One oiler can be found on the side of the dividing head which will carry the oil to the revolving spindle and one further oiler is to be found at the bottom near to the indexing handwheel which will carry the oil to the indexing plunger.

ADJUSTMENTS

The plunger movement is controlled to a large extent by the pressure of the supporting spring. If for any reason, after use, insufficient pressure is being exerted by the spring, there is a small supporting plate underneath the housing which can be detached by removing four screws. To increase the pressure of the spring, all that is necessary is to insert a washer behind the spring and over the small pin fitted to the plate. When leaving the works these springs are correctly adjusted and under normal usage it is extremely unlikely that this problem should arise.

WADKIN-REVLAC PRECISION DIVIDING HEAD (Continued)

ADJUSTMENTS—continued.

Adjustment is provided on the large circular nut to be found inside the dividing head to ensure that the maximum pressure is exerted when locking the indexing spindle in position by the indexing lever. This locking nut is adjusted when leaving the works and should give very long life before any adjustment should be necessary. However, should at some later date adjustment be necessary, two flats are provided on the lever which will enable the lever to be unscrewed and inserted into the next hole provided in the large locking nut. This nut can be seen through the slot in the main housing which, for the purpose of keeping out dust and grit, is covered by a rubber guard.

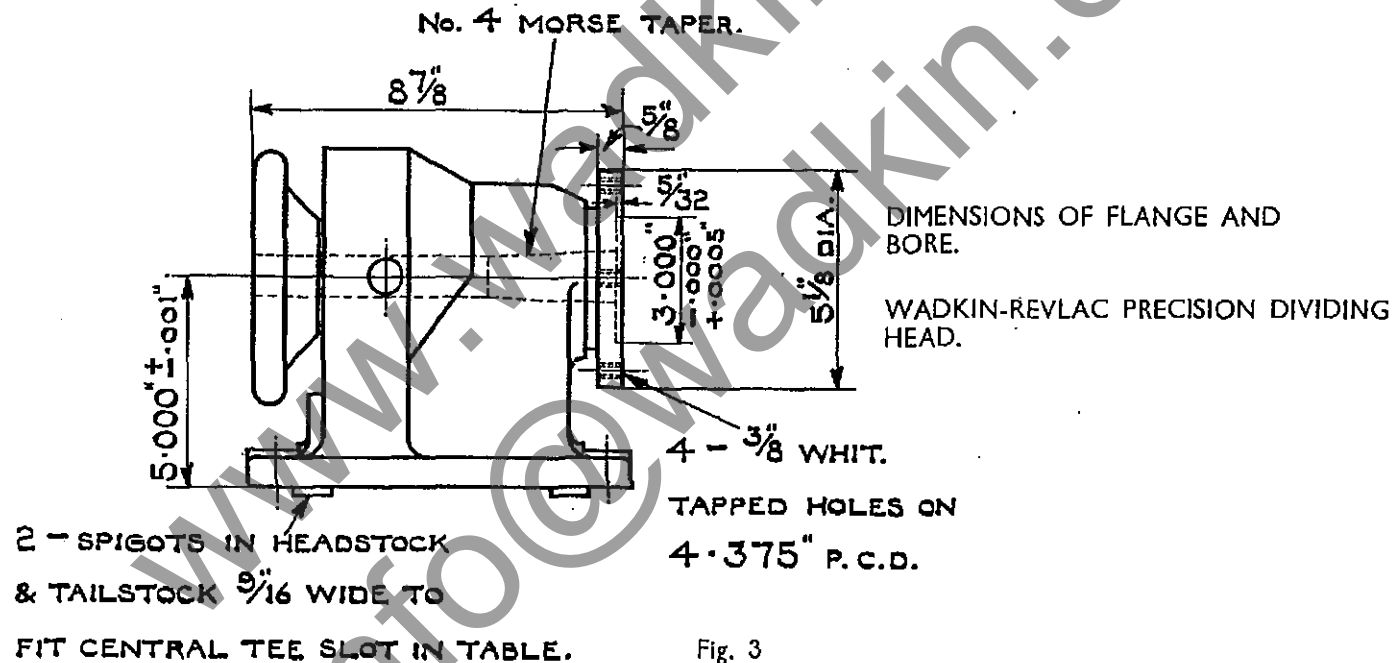

Fig. 3

ARBORS

The two arbors suitable for Wadkin moulder equipment are shown in Fig. 4. Arbor No. NH366 is suitable for 4", 7" or 8" moulder equipment, the 4" moulder blocks being positioned on the coned end of the arbor and locked in position with the coned sleeve and nut, as on the machine spindles. 7" and 8" equipment is mounted on the $1\frac{13}{16}$ " diameter portion of the arbor, the blocks being locked in position by means of the coned sleeve and nut on the block. Blocks can be taken from the machine spindles and mounted directly on the arbors.

Arbor No. NH365 is suitable for 7", 8" or 12" moulder equipment, all these blocks being locked directly on the arbor by means of the coned sleeve and nut on the block.

Additional arbors can be supplied to suit other sizes and makes of machines.

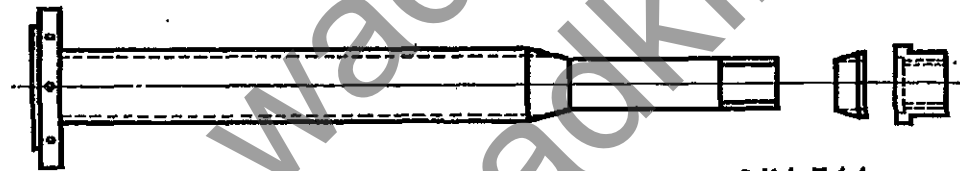

PART NO. NH 366.

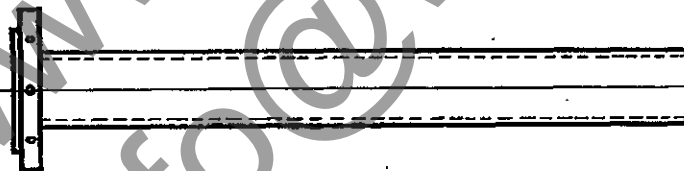

PART NO. NH 365.

ARBORS SUITABLE FOR WADKIN MOULDER EQUIPMENT.

Fig. 4.

ARBORS (Continued)

MOUNTING THE ARBOR ON THE DIVIDING HEAD

It is preferable, when fitting an arbor or mounting a block, that the machine table be held so that it cannot move longitudinally. This can be done on machines Nos. 123 to 194 by reversing the two table traverse limit stops so that the solid back part of the stops is engaging with the centre fixed stop and locking up in this position. This arrangement of the stops is seen in Fig.28. On machine No. 195 and onwards a small plunger bracket is fitted to the cross traverse slide, the plunger of which engages one of three holes in the machine table and thus locks the table longitudinally.

The sequence in which the arbor is mounted on the dividing head is shown in Fig. 5. It is essential that all the mating surfaces on arbors and dividing head are clean and free from dust or grit, otherwise misalignment of the arbor will occur, in which case the cutters will be ground out of truth.

- (1) Lock the machine table as described above.
- (2) Ensure that the machine table and the underside face of the dividing head are clean and free from dust and grit and bolt the dividing head firmly to the machine table, locating the spigots in the dividing head in the slot in the machine table and using the tee bolts supplied with the head.

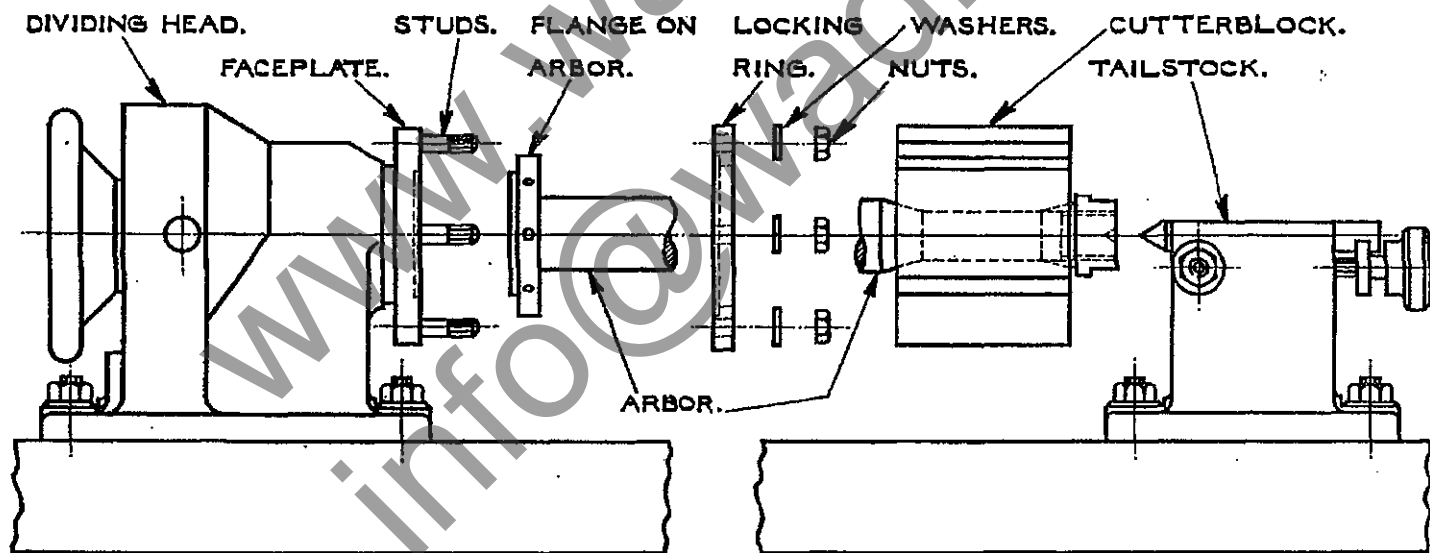

Fig. 5

ARBORS *(Continued)*

MOUNTING THE ARBOR ON THE DIVIDING HEAD *(Continued)*

- (3) Place the tailstock in position on the machine table but do not lock up.
- (4) Remove the nuts, washers and locking ring from the dividing head faceplate.
- (5) Insert the flange on the arbor into the recess in the dividing head faceplate.
- (6) Pass the locking ring over the arbor and on to the four studs projecting from the faceplate, ensuring that the recess in the locking ring fits over the flange on the arbor.
- (7) Fit washers and nuts to the four studs and lock up.
- (8) Slide the cutterblock on to the arbor (fit the cone and nut if it is a 4" moulder block) but do not lock up.
- (9) Slide the tailstock along the table until the dead centre in the tailstock engages the centre drilled hole in the end of the arbor, then lock the tailstock to the machine table.
- (10) Adjust the tailstock adjusting wheel until the centre is properly located in the arbor, then lock this adjustment up by means of the hexagon nut on the side of the tailstock body.
- (11) Lock the cutterblock firmly on to the arbor.

The arbor and cutterblock are now correctly mounted and the cutterblock ready to be set up for grinding.

SETTING UP FOR GRINDING

The setting up of a block for grinding will vary according to the type of block, the different set-ups for various blocks being dealt with further on in this booklet. For general work on square and circular blocks, peripheral milled cutterblocks, etc., the following will apply. The example, Fig. 6, shows a peripheral milled block from a 7" moulder being set up for grinding. After mounting the block on the arbor as described previously, release the table stops or plunger so that the table is free to move longitudinally. Slacken off the four screws locking the arbor to the faceplate, and by inserting the tommy bar supplied into the holes situated round the periphery of the flange on the arbor, the block can be turned radially to bring the face of the first cutter parallel with the face of the grinding wheel, as shown in Fig. 6.

SETTING UP FOR GRINDING *(Continued)*

By using the rise and fall motion on the head and the cross traverse motion on the table, combined with the radial motion on the arbor, the block should be set up so that the wheel edge is just touching the face of the cutter, the depth of the wheel being set so that the wheel will grind the full depth of face without touching the cutterblock body. When the block has been set satisfactorily the four nuts which lock the arbor should be locked up. One or two trial passes should now be made without running the grinding wheel, and the table limit stops set to give the length of stroke required, bearing in mind that the block must be completely clear of the wheel before it can be indexed round. The following points should now be checked. Dividing head and tailstock bolted firmly to table; arbor locked securely to faceplate; correct index setting made on dividing head; rise and fall motion to head locked; wheelhead set to zero and securely clamped in position; wheel guard in correct position; direction of rotation of wheel selected by switch (normally anti-clockwise). The set-up is now complete and is shown in Fig. 7.

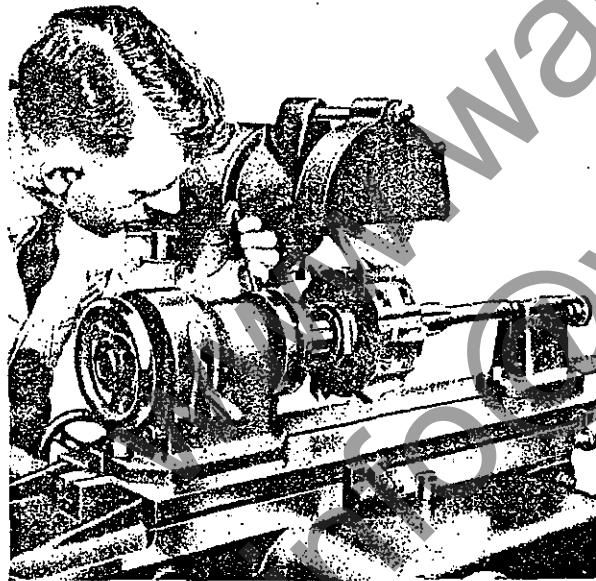

Fig. 6.

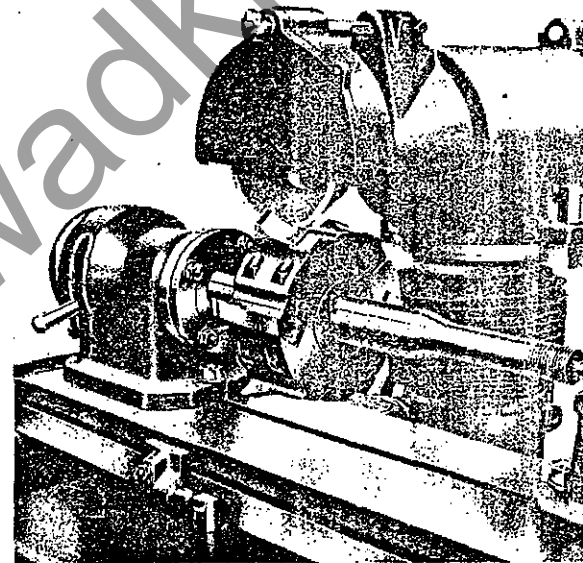

Fig. 7.

ALTERNATIVE METHOD OF INDEXING

If a cutterblock has not been initially machined very accurately, that is, a square block is not exactly square, or a circular block has the grooves for the knives inaccurately spaced, these inherent errors will be perceptible when the dividing head is used for indexing and it will not be possible to grind the block correctly. To overcome this difficulty an alternative method of indexing is supplied which consists of a steel finger carried from a bracket fixed to the machine table. The finger is set to locate behind the knife being ground and thus each knife will be located in the same relative position to the grinding wheel, thus cancelling out any of the above-mentioned errors. The set-up when using this finger indexing method is shown in Figs. 8 and 9, using the straight finger for square blocks and the curved finger for circular blocks.

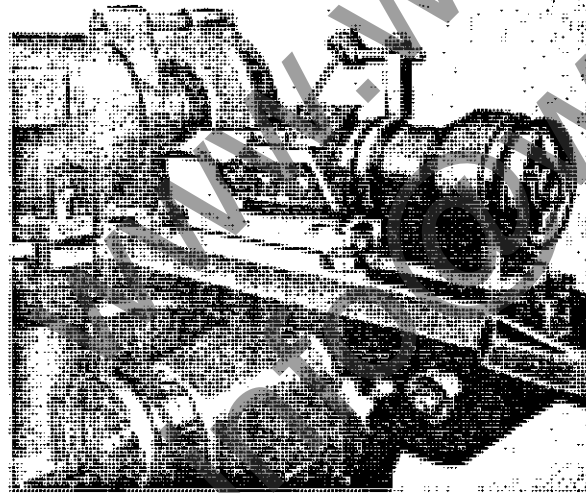

Fig. 8.

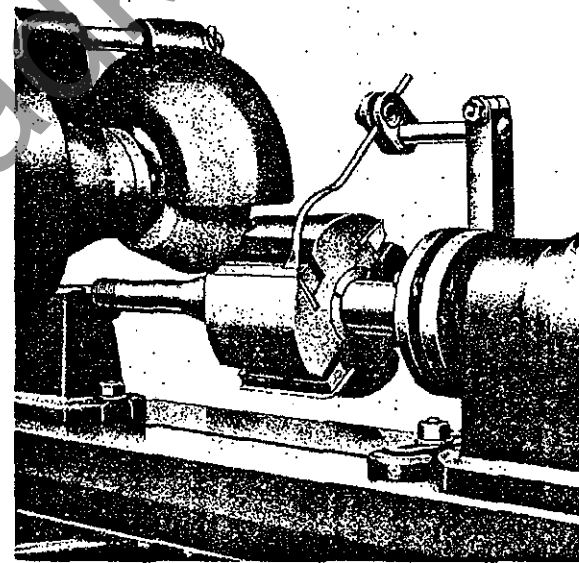

Fig. 9.

ALTERNATIVE METHOD OF INDEXING *(Continued)*

The indexing mechanism on the dividing head must be disengaged so that the head rotates freely, as described previously under the heading PRECISION DIVIDING HEAD. The set-up for grinding is as previously described except that a tee bolt for bolting the finger post bracket must be inserted into the tee slot, the finger assembly being located close up to the dividing head as shown in Fig. 8. The finger is set to locate at the back of the knife at such an angle that the finger will not foul the wheel guard whilst the block is passing the grinding wheel. The finger is spring-loaded, so that all that is necessary to index the next knife is to lift the finger clear of the knife and turn the block round by means of the indexing handwheel on the dividing head and locate the next knife up to the finger. When the knife is located in position the dividing head should be locked before grinding, by means of the locking lever.

GRINDING

To avoid excessive heat on the knives light cuts should be taken—not more than one or one-and-a-half thousandths of an inch per pass.

Take an initial roughing cut of one or one-and-a-half thousandths of an inch on one knife, indexing the block round until all knives have been ground. After grinding completely around the block, take successive light roughing cuts until all knives are sharpened. On the roughing cuts use a rapid table traverse.

On the finishing pass, reduce the cut to one-half thousandths of an inch and use a slow table traverse to ensure a keen cutting edge and uniform blade height. Keep the knives moving back and forth across the wheel face—this prevents localised heating. Finally check the setting of the knives on the setting-up stand and check balance.

APPLICATIONS

The illustrations on this and the following pages show the various types of grinding that can be done by using the attachments supplied for use on the machine.

The dividing head with suitable arbors will handle:—

Thick knives on square blocks, clearance bevel and face bevel.

Thin knives on circular blocks, clearance bevel and face bevel.

Milled to pattern bits on circular heads (see Figs. 6 and 7).

Matcher heads, clearance bevel and face bevel.

Bolinder type cutterheads, 2, 3, 4, 6 or 8 cutting points.

Fig. 10 shows the operation of grinding the clearance bevel on a four-knife square block.

To grind the face bevel, the block is simply reversed on the arbor and set-up as shown in Fig. 11.

Thin knives on circular blocks are ground in a similar manner as shown in Figs. 12 and 13.

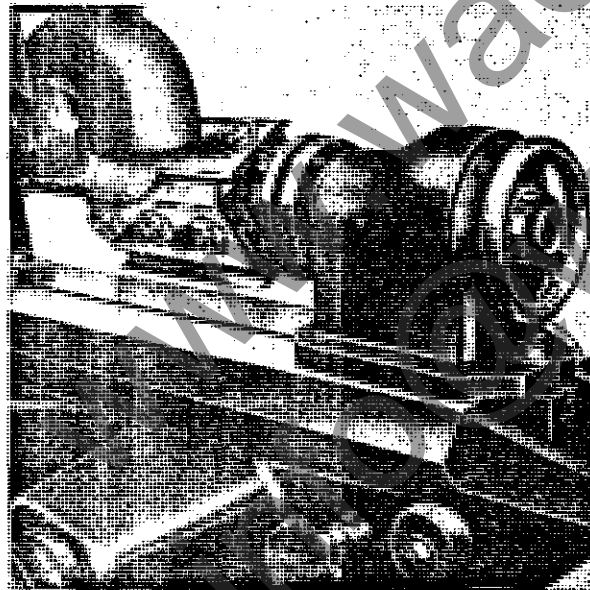

Fig. 10.

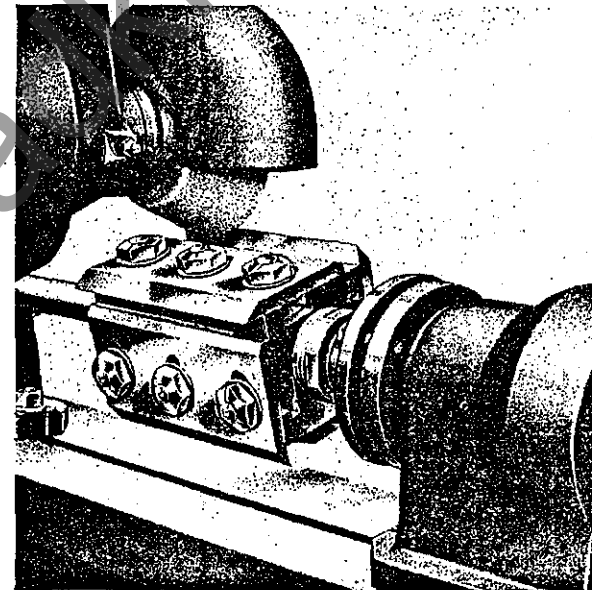

Fig. 11.

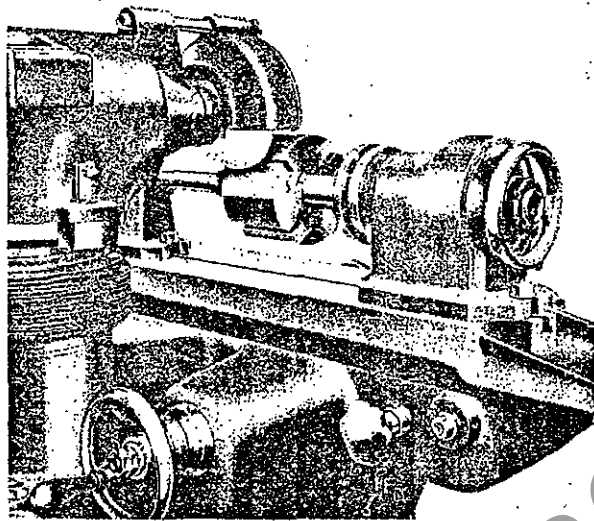

Fig. 12. Grinding clearance bevel—circular block.

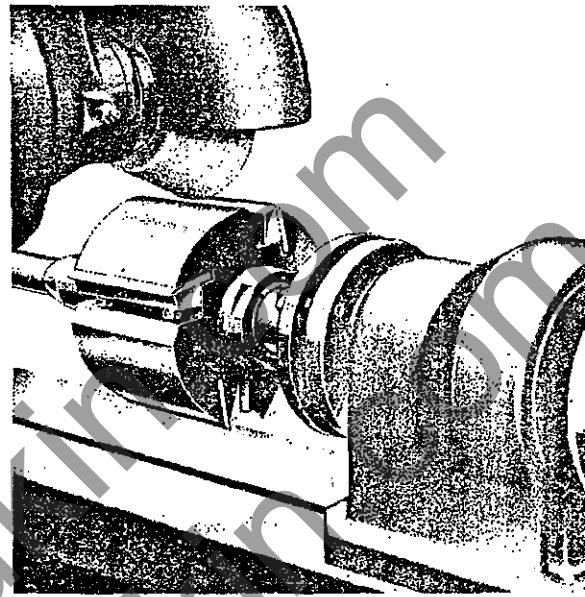

Fig. 13. Grinding face bevel—circular block.

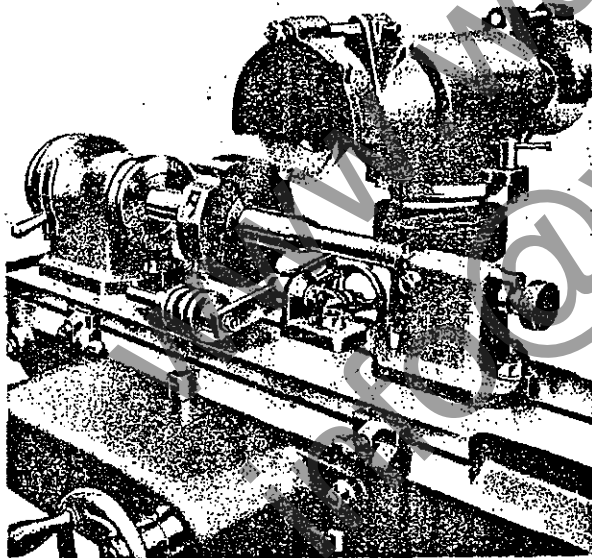

Fig. 14. Grinding clearance bevel—tonguing head.

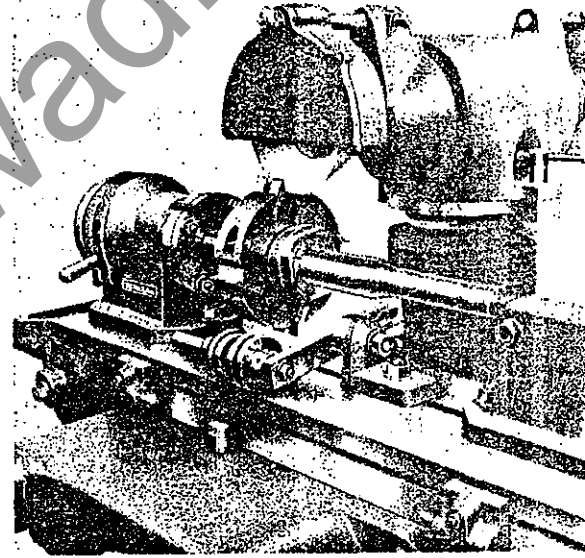

Fig. 15. Grinding face bevel—tonguing head.

NOTE.—Before grinding grooving heads, plug cutters should be removed.

APPLICATIONS *(Continued)*

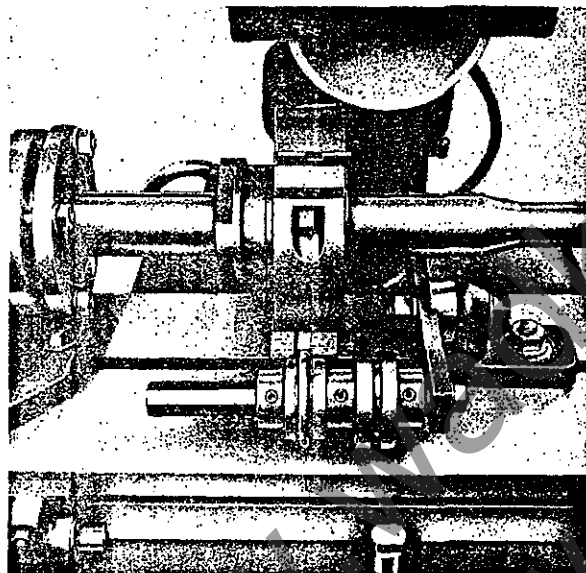

Fig. 16.

Vice grip cutterheads should be ground only on the front face as shown in Fig. 17. After repeated grindings, the knives can be extended along the slides in the cutterblock body to regain the original cutting circle.

After grinding the matcher head cutters, the roller setting attachment seen in Fig. 16 is used for setting the cutters in track. Provision is made on the attachment for setting both the tonguing and grooving heads. Various sizes of rollers can be made in hard wood by the operator to suit different settings required for various joints.

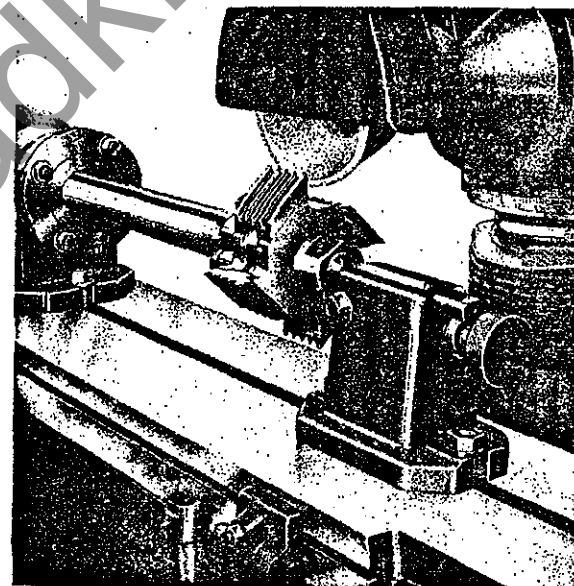

Fig. 17.

GRINDING BOLINDER TYPE SOLID PROFILE CUTTERHEADS

Sharpening is done by grinding off the front edges of the teeth. The tooth curve is shaped so that the correct profile is retained and the cutting points keep on the same periphery after grinding. To achieve this the same amount of material must be ground off the front edge of each tooth. The cutting angle of this type of cutterhead is usually 30° and, it is pointed out, this angle must not be altered as any alteration would give rise to differences in the tooth profile. The block, then, must be reground off the front edge of each tooth at the correct cutting angle. Supplied with the dividing head equipment is a small setting block suitable for this type of cutter with a cutting angle of 30° .

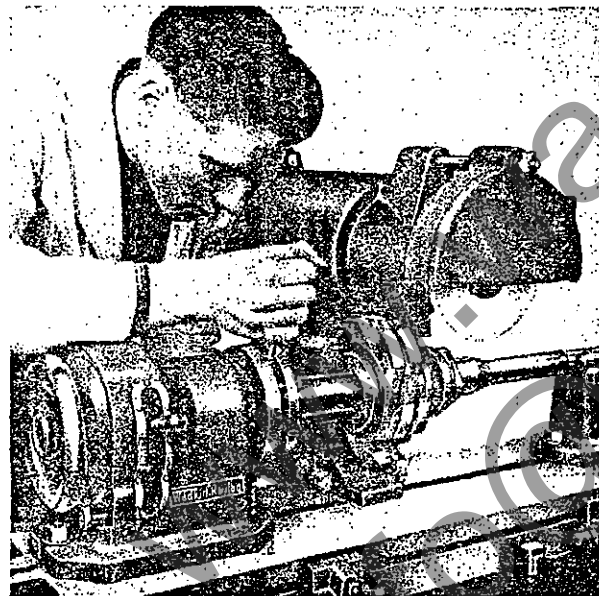

Fig. 18. Setting up for grinding a solid profile cutter showing block gauge used for setting the cutter at the correct angle for grinding.

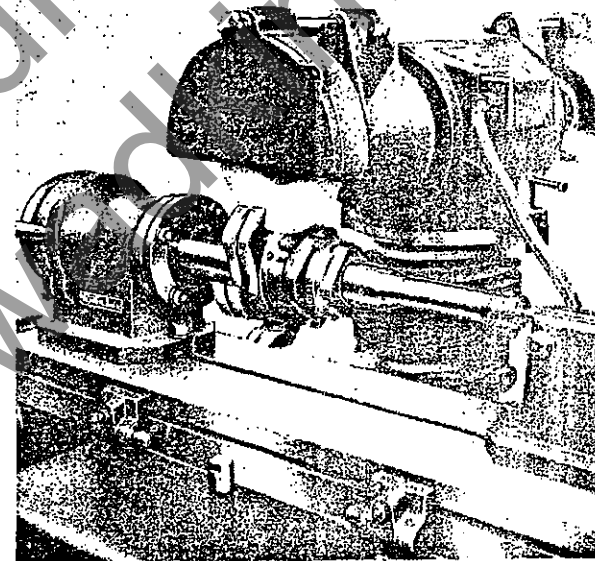

Fig. 19. After the initial setting (Fig. 18) the remaining cutters are precision located by the dividing head.

Procedure is as follows:—

- (1) Set the cutterhead on the arbor with dividing head correctly indexed for the number of cutting points as described previously. (Note : a dish-type grinding wheel is necessary for grinding this type of head.)
- (2) Insert the setting block into the tee slot in the table with the locating pad to the rear of the machine.
- (3) Slacken off the four screws holding the arbor locking ring, and by means of a tommy bar rotate the arbor until one cutting edge is just touching the pad on the setting block. This operation is shown in Fig. 18.
- (4) Lock the arbor firmly in position and remove setting block and commence grinding in the usual way. After the initial setting of the first cutting edge, the remaining edges are precision located by the dividing head. The completed set-up is shown in Fig. 19.

NOTE.—It is most important that each time a block of this type is set up for grinding initially, and for subsequent regrinds, the cutting edge must be set up to the setting block to ensure the correct cutting angle being developed.

DUMMY BLOCK OR LOOSE KNIFE GRINDING ATTACHMENT

The above attachment will enable both thick and thin knives to be ground separate from their blocks. The dummy block can be mounted on either of the two standard Wadkin arbors, part Nos. NH365 and NH366. If mounted on NH366 a small sleeve is required to accommodate the smaller diameter at one end of the arbor. This is supplied with the attachment. The dummy block should be mounted on the arbor with the machined face facing the grinding wheel and the tee slot at the top. It should be bolted firmly on the arbor by the two split grip locks. A suitable index for the dividing head is 4, so that one position locates the block for grinding and a position 90° to this is maintained for setting and bolting the cutters in position. If thick knives are to be ground, these are bolted directly on to the dummy block with the tee bolts provided. Thin knives are clamped in position using the clamps as shown in Fig. 22. The knives, both thick and thin, are set in position on the dummy block using the setting blocks supplied. The knife should be set to give a minimum of projection above the top of the dummy block. By setting the knife to the block gauges as shown in Fig. 20 (to be removed before grinding) it ensures that the knife is ground parallel and that all knives in the same set are the same height. When the knife has been bolted on to the dummy block the arbor is rotated radially, as previously described, to present the clearance angle of the knife parallel to the face of the grinding wheel, the arbor is then locked in position and the knife is then ready to be ground as shown in Fig. 21.

DUMMY BLOCK *(Continued)*

Face bevels can be ground on thick or thin knives on the dummy block simply by reversing the block on the arbor, i.e., machined face facing away from the wheel and tee slot at the top. The set-up is then similar to that shown in Fig. 11 except that the dummy block is used. The knife is fixed to the dummy block in exactly the same manner as for grinding clearance bevel. On the 24" machines the dummy block is not carried by the dividing head but is carried on a vee block support at each end and indexed by the finger attachment. Otherwise the method of setting up and grinding is the same as for the 12" machine.

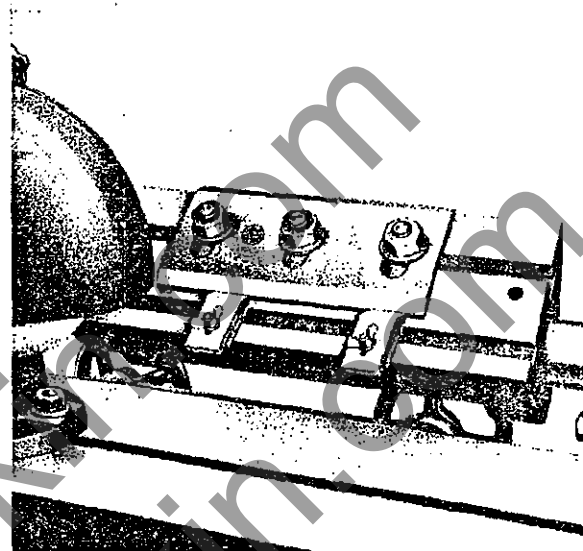

Fig. 20.

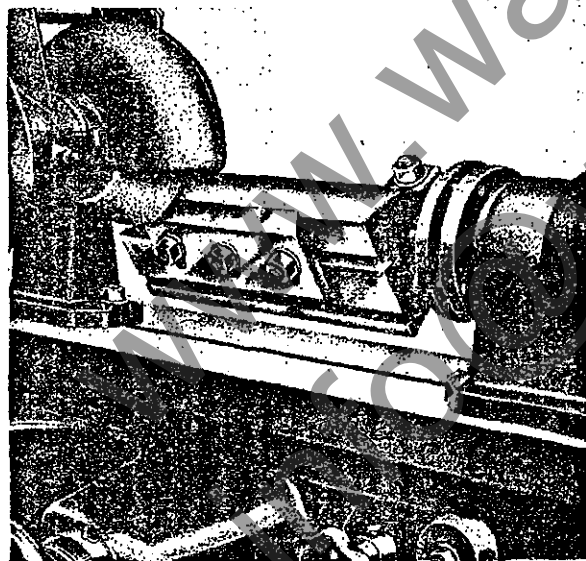

Fig. 21. Thick knife set-up for grinding on dummy block.

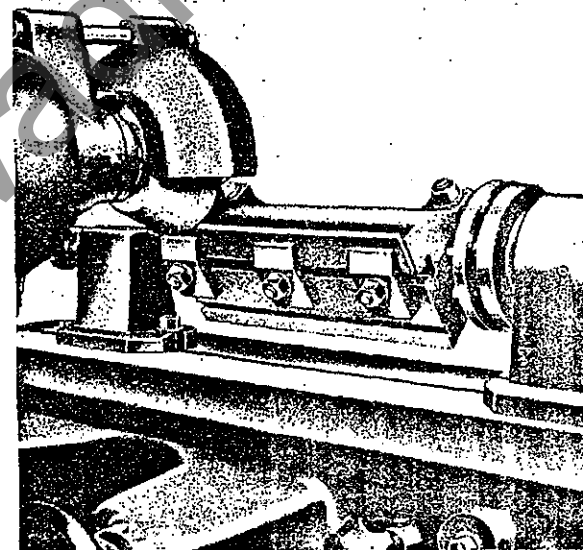

Fig. 22. Thin knife set-up for grinding on dummy block.

HOLLOW GRINDING

Hollow grinding can be done, as shown in Fig. 23, on thick or thin knives on the dummy block by swivelling and lowering the head to its lowest position so that the knife is as near to the centre line of the wheel as possible. Hollow grinding can also be done on knives on square blocks, Fig. 10.

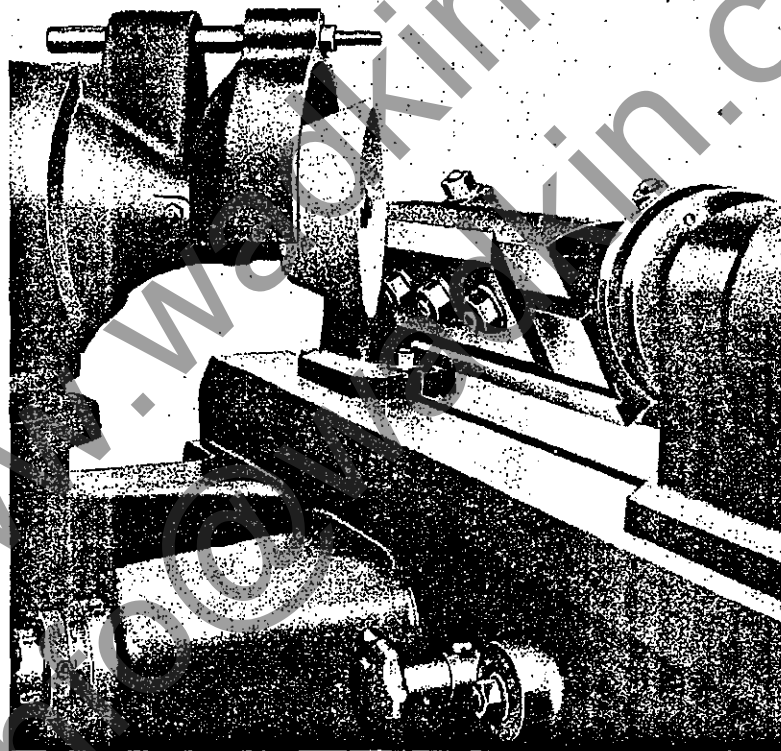

Fig. 23.

ROUTER CUTTER GRINDING ATTACHMENT

This attachment consists of an auxiliary table plus fixtures required to suit the various router cutters. A range of 4" diameter grinding wheels of various shapes is available to suit the different types of router cutters (see list on page 10).

The auxiliary table is bolted to the machine table using the tee bolts supplied, as shown in Fig. 24. The fixtures are bolted to the auxiliary table, some examples being shown in Figs. 25 and 26 below.

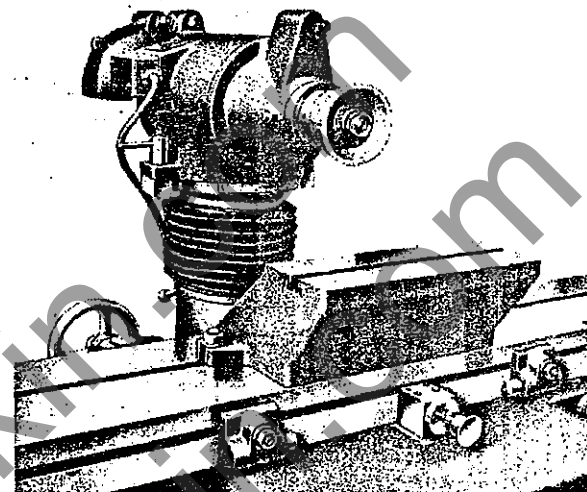

Fig. 24. The auxiliary table and grinding wheel in position.

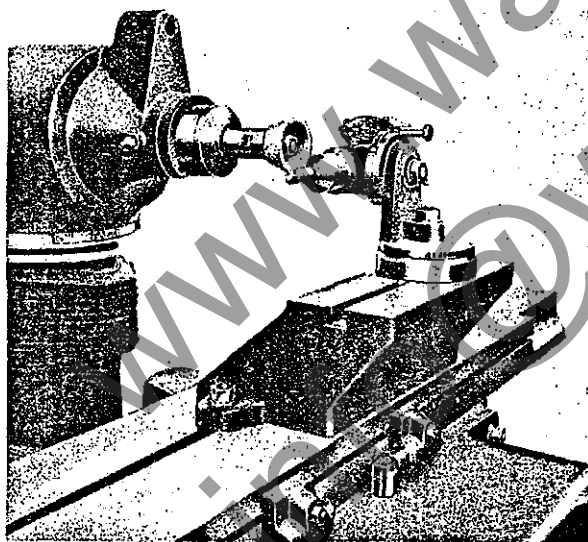

Fig. 25. Grinding a straight fluted cutter on attachment type SFA.

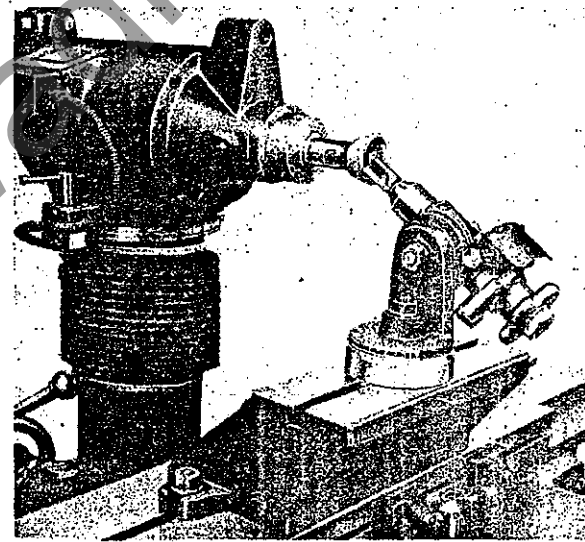

Fig. 26. Grinding the end of a cutter on attachment type SFA.

WHEEL DRESSING ATTACHMENT

The attachment shown in Fig. 27 is designed to carry a diamond which is passed backwards and forwards across the revolving grinding wheel by means of the longitudinal movement to the table. The diamond should be set in the holder to point downwards at an angle of approximately 10° to 15° and the wheel must revolve downwards on the side that the dresser is being used. In Fig. 27 the wheel would be revolving in an anti-clockwise direction.

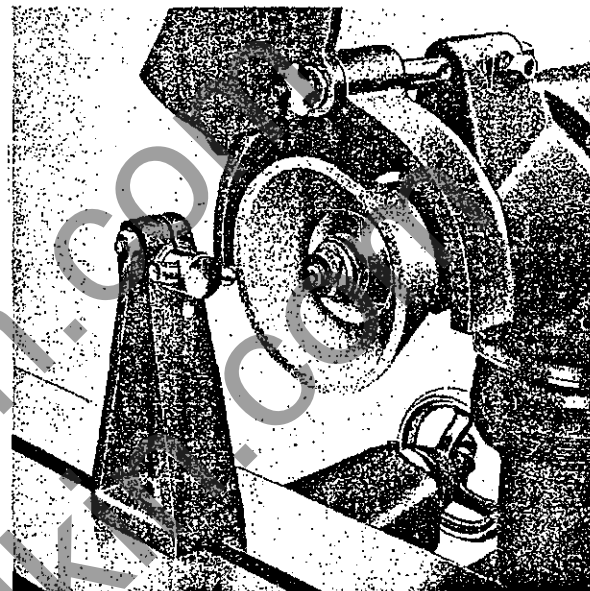

Fig. 27.

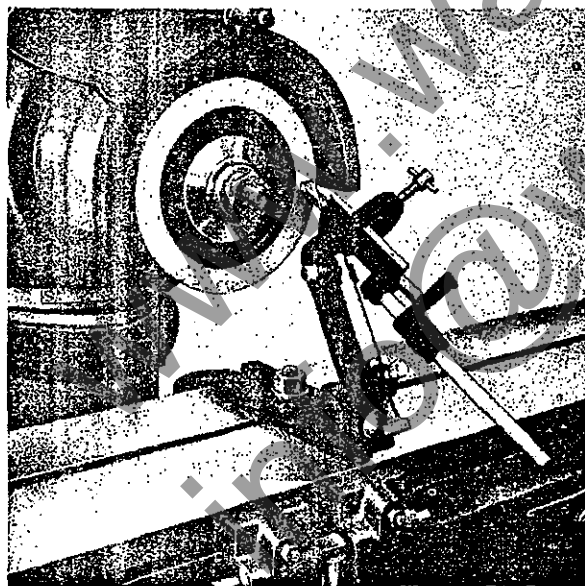

Fig. 28.

TWIST DRILL GRINDING ATTACHMENT

The attachment is bolted to the machine table and a 6" diameter cup wheel UGW170 is mounted on the spindle. The table must be constrained from longitudinal movement by one of the methods described on page 14 under "MOUNTING THE ARBOR ON THE DIVIDING HEAD". The arrangement is shown in Fig. 28. Complete illustrations and instructions for use are supplied with each attachment.

SWIVELLING TABLE ATTACHMENT

This attachment is to cater for the grinding of skew type or shear cut blocks up to 12½" long, and also is suitable for grinding taper cutters

The table will swivel 10° either way.

To set the table up on the machine it is first necessary to fix the register on which the table swivels. This is locked in the position marked on the machine table by using the box spanner as shown in Fig. 29.

The swivelling table is now placed in position locating on the register, and a clamp fitted at each end of the table, being carried from a tee bolt in the tee slot in the table.

The dividing head, tailstock, arbor and block are then mounted on the swivelling table. In this arrangement the knife is ground using the periphery of the wheel and not the face, the wheel being shaped by using the dresser, Fig. 27, to the shape indicated in Fig. 30 to suit the clearance angle of the knife. The table is then swivelled over until the full length of the knife will pass under the wheel, then locked in position, the general set-up being as shown in Fig. 31.

Grinding is then carried out in the usual manner, depth of cut being obtained by lowering the head very slightly.

Alternatively, this operation can be done following the method laid down for grinding adze cutters on tenon blocks, but without using the swivelling table.

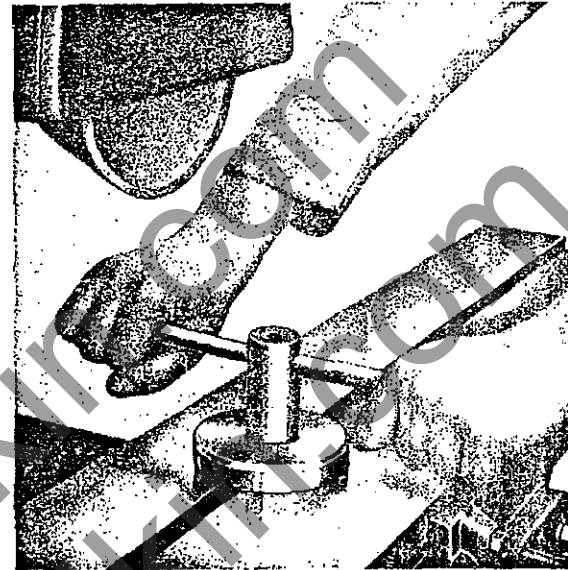

Fig. 29.

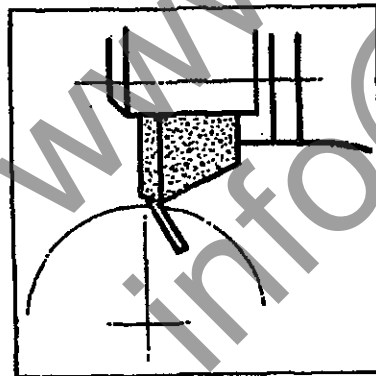

Fig. 30.

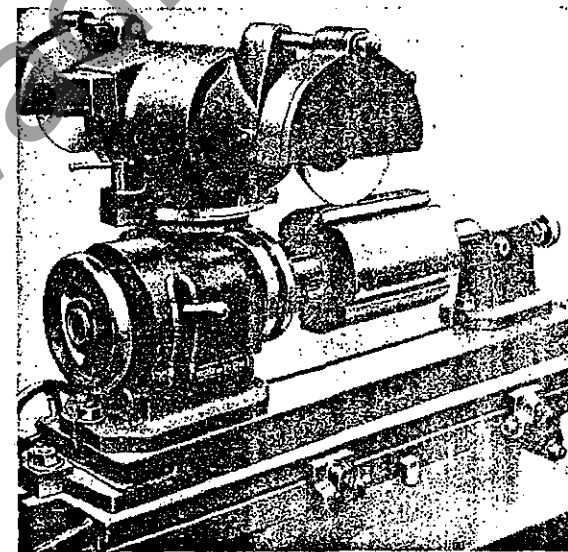

Fig. 31.

TENON BLOCK ADZE CUTTER GRINDING ATTACHMENT

This attachment provides an accurate method of grinding and maintaining the correct shape of the adze cutters by mechanical methods. It consists of a fixed finger working along the edge of the cutter, the cutterblock assembly being mounted on the swivelling table. The standard arbor supplied with the attachment will accommodate any Wadkin tenon block.

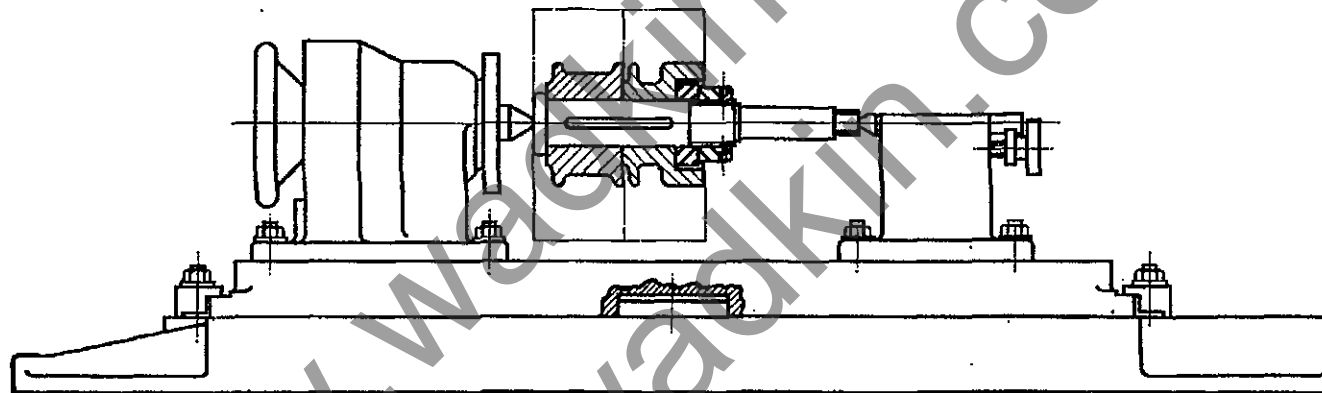

Fig. 32.

Fig. 32 shows the mounting of the blocks from the following machines, both halves of the block being mounted : EK, EKA, EL, EM, WA, WB, WF. Blocks from machines EC, EH, EJ and EO are mounted in a similar manner on the $1\frac{1}{4}$ " diameter portion of the arbor. The swivelling table is mounted on the machine table, as described on page 28, dividing head and tailstock then being placed in position. A No. 4 Morse taper dead centre is now fitted into the bore of the dividing head, the arbor complete with blocks being mounted between the two centres in the head and tailstock giving the complete table assembly as shown in Fig. 32. The dividing head will not be used for indexing purposes so this can be locked. The screws holding the spur cutters in the tenon blocks should be loosened and the spur cutters dropped below the cutting circle diameter. This is to prevent the spur cutters fouling the grinding wheel during the grinding operation.

TENON BLOCK ADZE CUTTER GRINDING ATTACHMENT (Continued)

The finger assembly is now set up as shown in Fig. 33. The tip of the finger should be set approximately $\frac{3}{4}$ " below the centre of the wheel, on the cutting side of the wheel (left-hand side with the wheel running clockwise) and $\frac{1}{32}$ " away from the wheel as shown in diagram Fig. 34.

Generally, tenon blocks are made slightly conical and due to this the swivelling table must be set over to give this coned effect, as shown exaggerated in Figs. 35 and 36. The amount that the table is set over depends upon the make of block, but for Wadkin blocks the amount is one division of the scale on the left-hand side of the swivelling table, equal to a movement of $\frac{1}{16}$ ".

The direction in which the table is set over depends upon which way the block is coned. On all Wadkin blocks the spur cutter end of the block is the bigger diameter, therefore the settings are as shown in Figs. 35 and 36.

NOTE.—It is recommended that when a block has been ground, tried on the setting-up stand and found correct, that the position of the swivelling table relative to the machine table be marked by scribe lines to facilitate easier and quicker set-ups for subsequent regrinds.

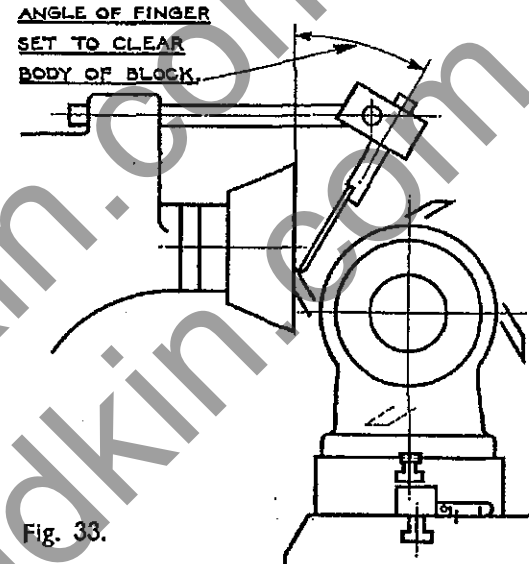

Fig. 33.

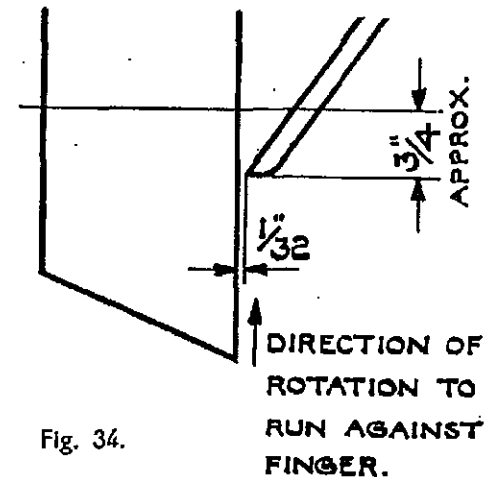

Fig. 34.

TENON BLOCK ADZE CUTTER GRINDING ATTACHMENT (Continued)

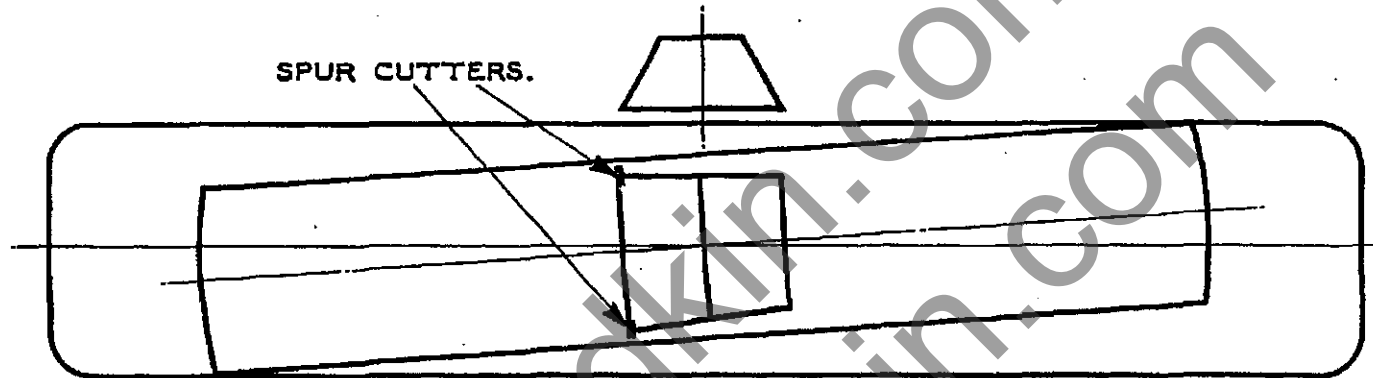

Fig. 35.

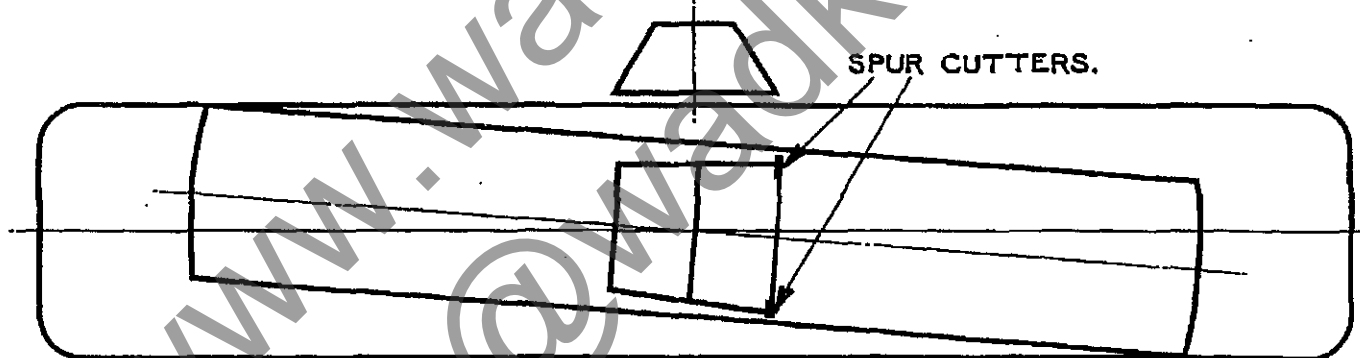

Fig. 36.

The edge of the first knife should now be set between the finger and the wheel, and by means of the rise and fall and cross traverse to table, the knife should be brought into a position to give the correct grinding angle. The knives are now ready to be ground. Keeping the left hand on the tenon block and pressing the knife lightly back on to the finger, the right hand is used to traverse the table longitudinally, as shown in Fig. 38.

Take an initial roughing cut of one or one-and-a-half thousandths of an inch on one knife, turn the block round to the next knife and take the same cut, proceeding thus until all knives have been ground. After grinding

TENON BLOCK ADZE CUTTER GRINDING ATTACHMENT

(Continued)

completely round the block, take successive light roughing cuts until all knives are sharpened. On the roughing cuts use a rapid table traverse. On the finishing pass, reduce the cut to one-half thousandth of an inch and use a slow table traverse to ensure a keen cutting edge and uniform blade height. Finally check the setting of the knives on the tenon block setting stand.

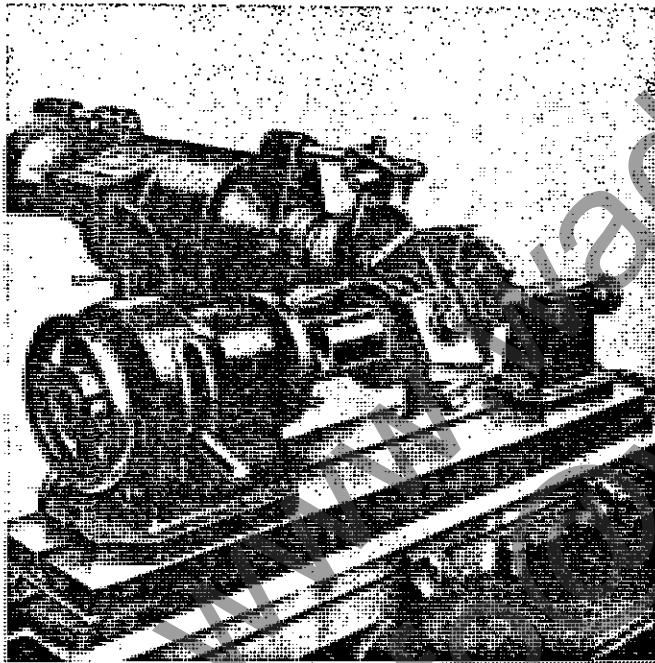

Fig. 37. Showing the tenon blocks set up for grinding.



Fig. 38. Showing the actual operation of grinding, indicating the best position for the operator.

TUNGSTEN CARBIDE TIPPED SAW GRINDING ATTACHMENT

This attachment is designed to do square or bevel topping and facing separately on tungsten carbide tipped saws from 8" to 18" diameter, from 1" to 2 $\frac{1}{4}$ " bore. Grinding must be done with special grinding wheels, listed on page 9, but sharpening can be done by using a diamond impregnated wheel, details of which are dealt with further on in this booklet.

The saw is positioned in self-centring bushes and clamped by a spring-operated clamp near its periphery. For plate saws the height of the self-centring bush should be set level with the face of the bottom clamping pad. For saws that are thicker on the boss than on the teeth the self-centring bush must be adjusted in order to allow the saw to sit flat on the bottom clamping pad. To adjust the height of the self-centring bush, slacken off the hexagon hole capscrew A, Fig. 39 and rotate the circular nut B, this will enable the saw to be raised or lowered into position. When set in position relock capscrew 'A'.

The self-centring bushes should be set to suit the diameter of saw being ground, that is, with the gullet of the saw projecting just clear of the clamping pads. This is done by inserting a tommy bar into a hole 'B' in the periphery of the flange, slackening off and moving the post along the cored slot then relocking.

If square topping or facing is to be done the table should be set at zero, indicated on scale 'C', dowel 'D' inserted and nuts 'E' locked. If bevel topping or facing is to be done the dowel 'D' should be removed, nuts 'E' released and the table canted to the correct amount as indicated on scale 'C'. Nuts 'E' should then be relocked. Fig. 40 shows the fixture set up for this operation.

To set the saw to the correct grinding angle, swivel the quadrant the required amount as indicated by pointer 'G' on the scale 'L', see Fig. 44, and lock in position with handle 'F', Fig. 39. Scale 'L', Fig. 44, is graduated 0° to 25° for topping or clearance angle, Fig. 44, and 0° to 35° in either direction for face angle or angle of hook, Figs. 45 and 47.

The saw is indexed when grinding by a flattened pin 'H' which is presented to the saw teeth by depressing the lever 'J'. The flattened portion of this pin should be set initially so that it lies parallel to the face of the saw tooth as shown in Fig. 44. This can be done by slackening the hexagon hole grubscrew 'K', Fig. 39, depress lever 'J', line up pin with face of saw tooth, relock grubscrew 'K' and release the lever.

TUNGSTEN CARBIDE TIPPED SAW GRINDING ATTACHMENT

(Continued)

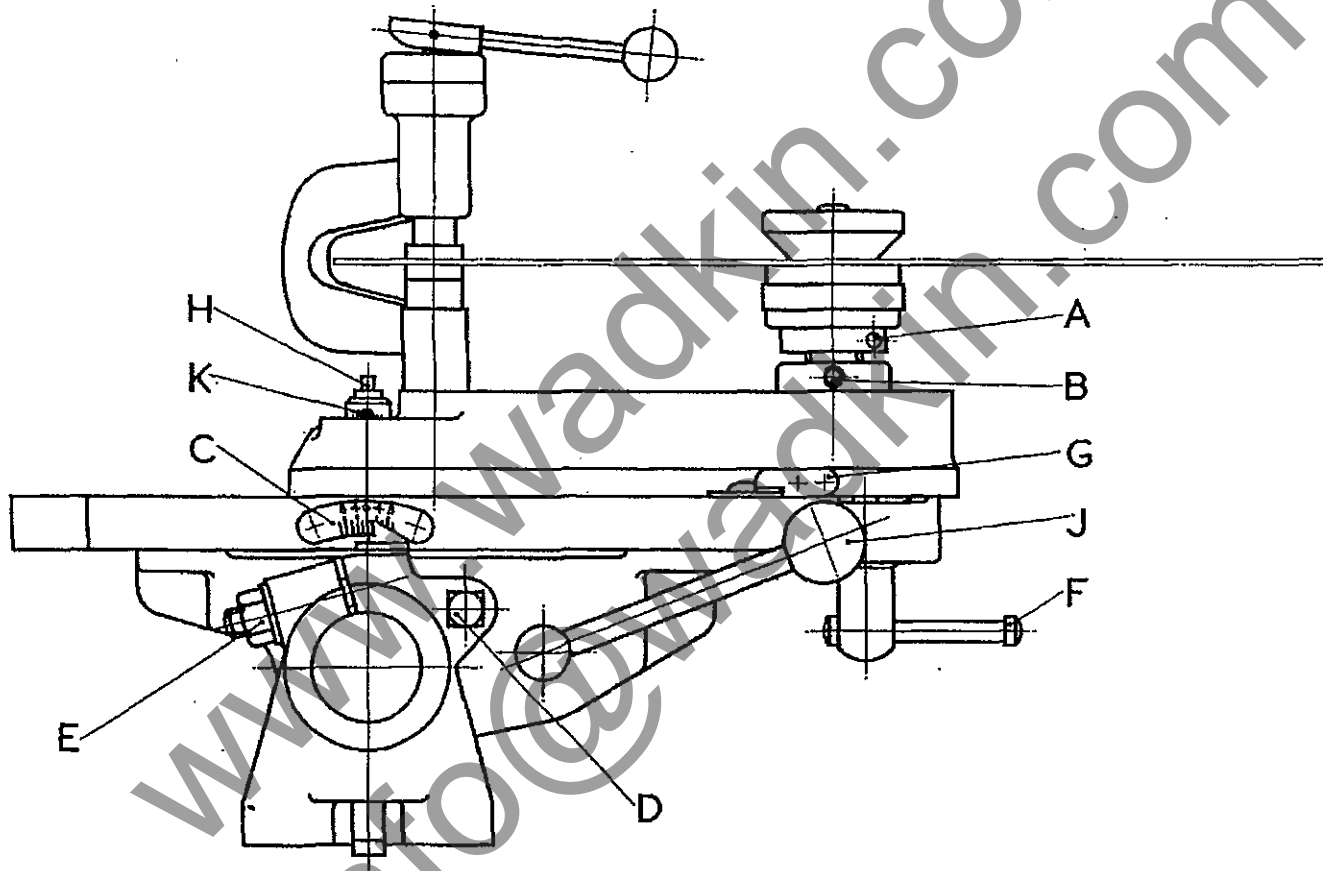

Fig. 39.

TUNGSTEN CARBIDE TIPPED SAW GRINDING ATTACHMENT

(Continued)

PROCEDURE FOR GRINDING

To index the first tooth, traverse the table up to the stop so that the saw is clear of the wheel, release the clamp, depress the plunger lever and locate the face of the tooth to be ground. Release the plunger lever and clamp the saw. This operation is shown in Fig. 43.

Grind the first tooth taking a cut of one-half thousandth of an inch. Leave the cross traverse set at this and proceed to grind the remainder of the saw teeth, after which a further cut can be put on if necessary.

It should be noted that if a bevel is being ground, each alternate tooth is ground, then the attachment canted over in the opposite direction and the remainder of the teeth ground to give the opposite bevel.

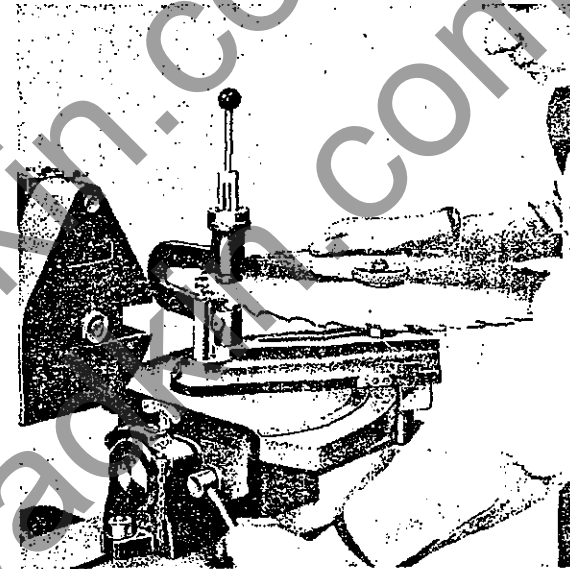

Fig. 43.

TO SET UP FIXTURE FOR GRINDING FACE ANGLE

There are two ways of setting up for this operation. The method chosen will depend upon the diameter of the saw and the face angle or angle of hook. Referring to the graph, Fig. 46, if the intersection of the lines "SAW DIAMETER" and "ANGLE OF HOOK" lies within the lower portion of the graph, the front face of the saw can be ground by setting up as in Fig. 45. If the intersection of the two lines lies in the upper portion of the graph then the set-up must be as shown in Fig. 47. Note that in this set-up the diamond wheel must be reversed on the spindle.

TO SET UP FIXTURE FOR GRINDING OR SHARPENING CLEARANCE ANGLE (Fig. 44)

- (1) For grinding operation mount a wheel No. UGW168 or 169, described on page 9, and sheet iron guard. For sharpening operation, mount the diamond wheel, guard and oil pad. (This is described further on in this booklet.)
- (2) Bolt the attachment firmly on to the machine table.
- (3) Open clamp and mount the saw on the self-centring bushes.
- (4) Cant the table over to the required degree for angular topping. If square topping, ensure that the table is set at zero, with the locating dowel in position.
- (5) Set the quadrant to give the necessary clearance angle.
- (6) Set indexing pin so that the flattened portion of the pin lies along the face of the tooth.
- (7) Set the table limit stops to give the required table movement.
- (8) Run the wheel in a clockwise direction.

The attachment is now set up for grinding clearance angle and is shown in Fig. 41.

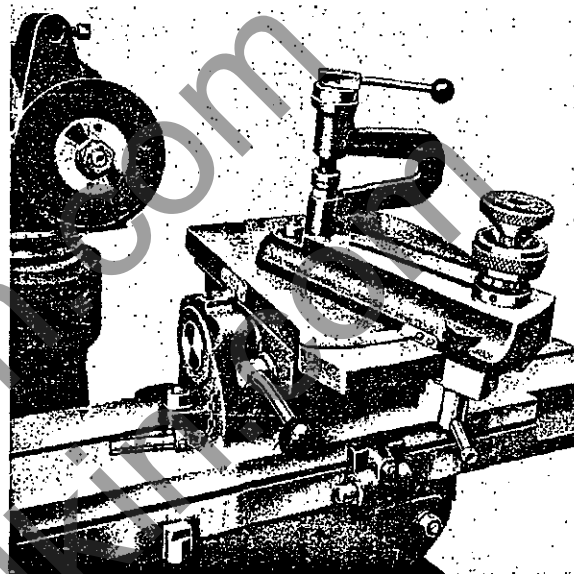

Fig. 40.

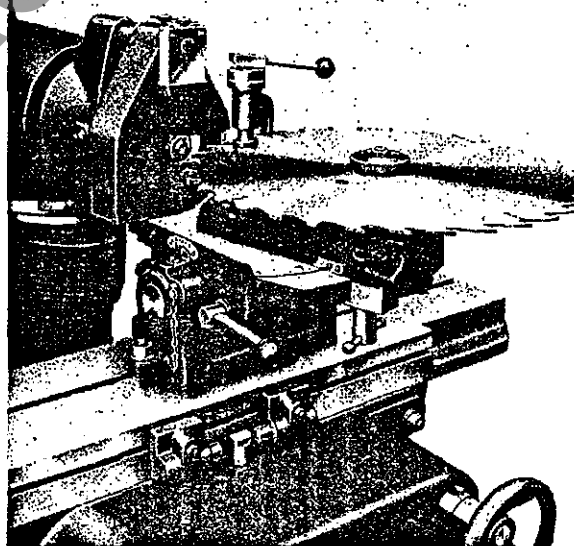
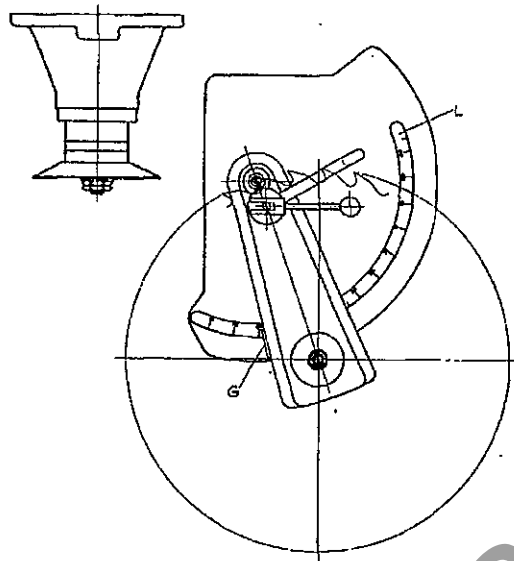
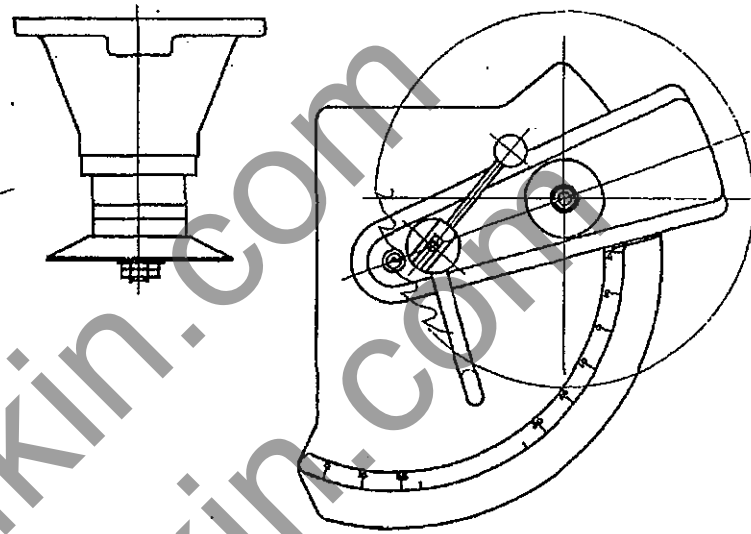

Fig. 41.



SET-UP FOR GRINDING CLEARANCE ANGLE

Fig. 44.



SET-UP FOR GRINDING FRONT FACE

Fig. 45.

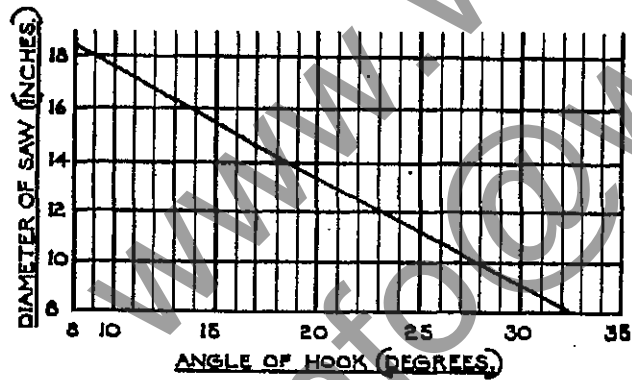
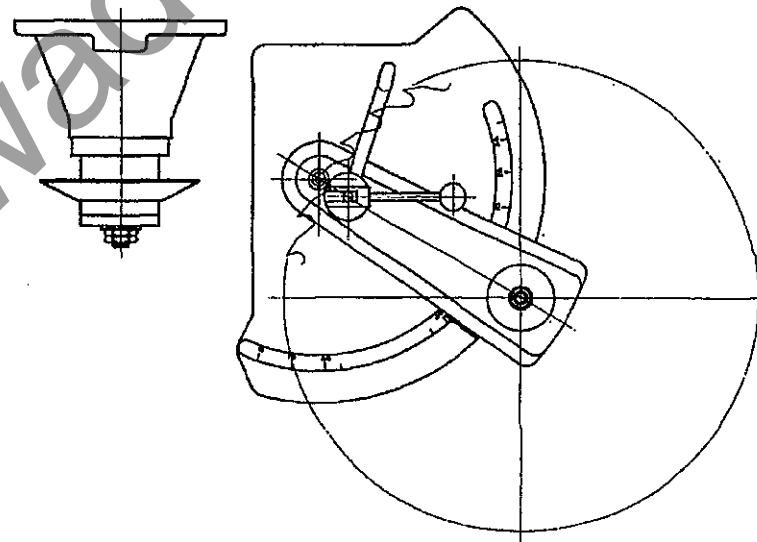

Fig. 46.



SET-UP FOR GRINDING FRONT FACE (WITH WHEEL REVERSED)

Fig. 47.

GRINDING TUNGSTEN CARBIDE TIPPED CUTTERS AND SAWS

Tungsten carbide tipped cutters cannot be sharpened with ordinary grinding wheels or honed with carborundum honing stones. They are ground with silicon carbide (green grit) wheels which are listed on page 9. After rough and finish grinding with these wheels, it is recommended, in order to get the best cutting edge, that they are finally finished with a diamond wheel.

DIAMOND WHEELS

These wheels are made of a resinoid bonded material and the cutting edge is impregnated with diamond grains. Due to the expensive nature of these wheels they should only be used for final finishing. It is essential that these wheels be mounted on a steel mounting bush as shown in Fig. 48, for reasons of economy and accuracy, and that the wheel is kept on its individual bush throughout its life.

Dressing of these diamond wheels is seldom necessary and should be avoided as far as possible.

A thin mineral oil should be used as a coolant on this type of wheel and this is applied by means of a felt pad lightly pressing on the wheel face, as seen in Fig. 41. The pad is supplied with oil from the small reservoirs in the steel block on which it is mounted. To fill the reservoirs remove the two screwed plugs in the top of the steel block and fill with Wadkin oil grade L1. Keep these reservoirs topped up when using the diamond wheel. Applications of the diamond wheel and oil pad are shown in Fig. 49.

IMPORTANT.—The depth of cut when using a diamond wheel should never exceed one thousandth of an inch.

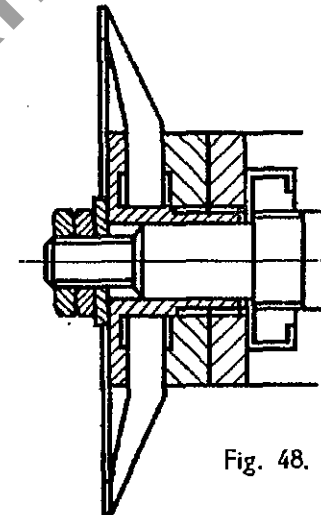
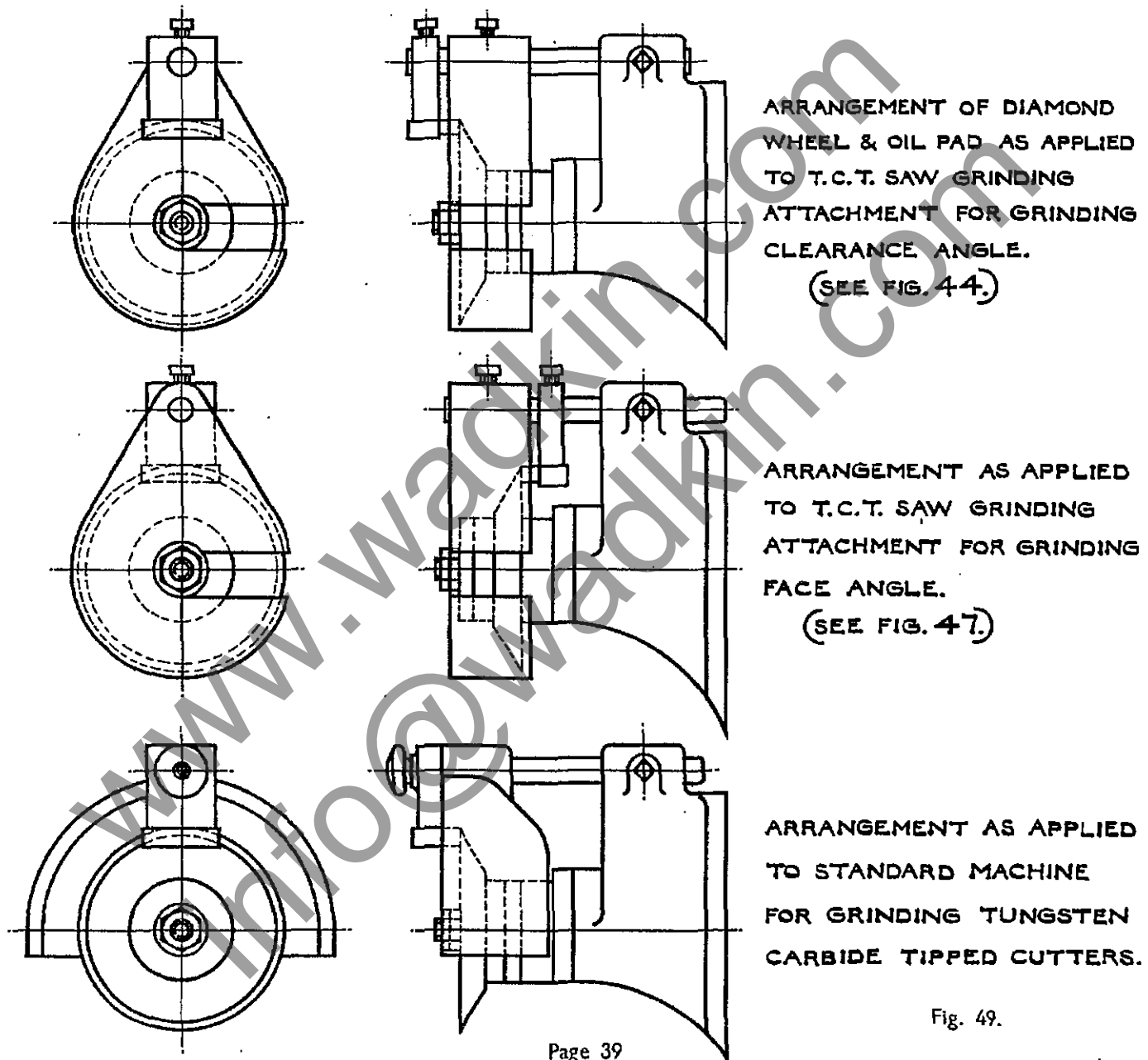

Fig. 48.



GRINDING SHEAR CUT SOLID PROFILE CUTTERS

Sharpening is done by grinding off the front edge of the teeth. The tooth curve is shaped so that the correct profile is retained and all the cutting points keep on the same periphery after grinding. To achieve this the same amount of material must be ground off the front edge of each tooth. The cutting angle of this type of cutterhead is usually 30° and it is pointed out that this angle must not be altered, as this would give rise to differences in the tooth profile. The block, then, must be reground on the front edge of each tooth at the correct cutting angle. To maintain this angle the cutter must be fed into the wheel radially. This is affected by fitting an arbor with a radial feed attachment. By this means the original cutting angle and profile can be maintained. This type of arbor is shown in Fig. 50. To set the cutter a setting plate is used as this is more accurate than the narrow edge of the dished wheel.

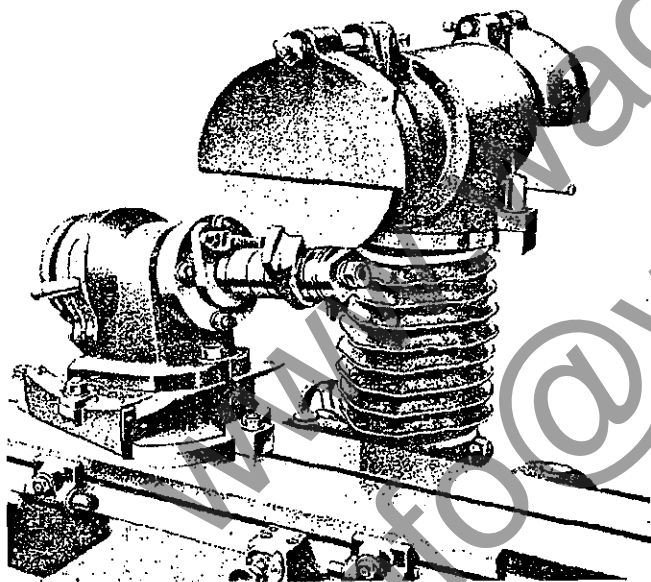

Fig. 50. Setting up for Grinding.
A solid profile cutter is shown located against the setting plate and is now at the required angle for grinding.

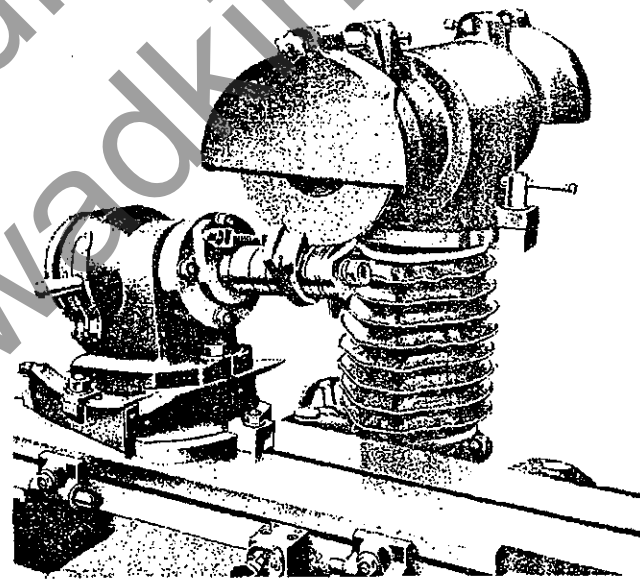

Fig. 51. After the initial setting the cutting edges are presented to the grinding wheel in turn, being located correctly by the dividing head.

GRINDING SHEAR CUT SOLID PROFILE CUTTERS (Continued)

Procedure is as follows :

- (1) From the grinding spindle carrying the dished wheel, remove the locknuts and washer which hold the wheel in position. Do not remove the wheel. Place on the spindle the setting plate and replace washer and nut.
- (2) Fix to the left-hand end of the machine table the register about which the swivelling base for the dividing head revolves. (Fig. 29).
- (3) The bore in the swivelling base should be placed over the register and the base held to the table by tee bolts in the table tee slot. Lock in position by clamp nuts.
- (4) Place the canting slide on the swivelling base and lock by hexagonal nuts.
- (5) The dividing head should now be placed on the canting slide and bolted in position.
- (6) Add complete arbor to the dividing head faceplate, keeping the radial feed screw at the top.
- (7) Place cutter on the arbor and position by loose collars. Screw on nut "A" finger tight.
- (8) Release clamp nuts on swivelling base and canting slide, traverse the wheelhead and table until the cutter face lies flat on the setting plate. (Fig. 50).
- (9) Carefully lock the canting slide, swivelling slide and nut "A". Check that the cutter has not moved out of alignment.
- (10) Remove setting plate and relock wheel.
- (11) Set dividing head index for number of faces to be ground.
- (12) Traverse wheelhead and table until wheel just touches cutter (Fig. 51), lock table cross slide and traverse table until wheel is clear of cutter. Apply radial feed by rotating screw "C" one division in a clockwise direction. Lock-nuts "B" do not require moving.
- (13) Take an initial cut on one knife, then index block round until all the knives have been ground. Apply more radial feed and proceed in a similar manner until block is satisfactorily ground.

NOTE : To ensure accurate setting the grinding wheel face should be kept true and the setting plate clean.

HIGH SPEED GRINDING ATTACHMENT FOR ROUTER CUTTERS

This high speed grinding attachment, type NHG is for dealing with all kinds of router cutters. It is particularly suitable where the quantity of router cutters to be maintained is rather heavy. The spindle revolves at 5000 r.p.m. mounted on precision ball bearings and driven by a special nylon endless belt to give an efficient and satisfactory speed to the grinding wheels.

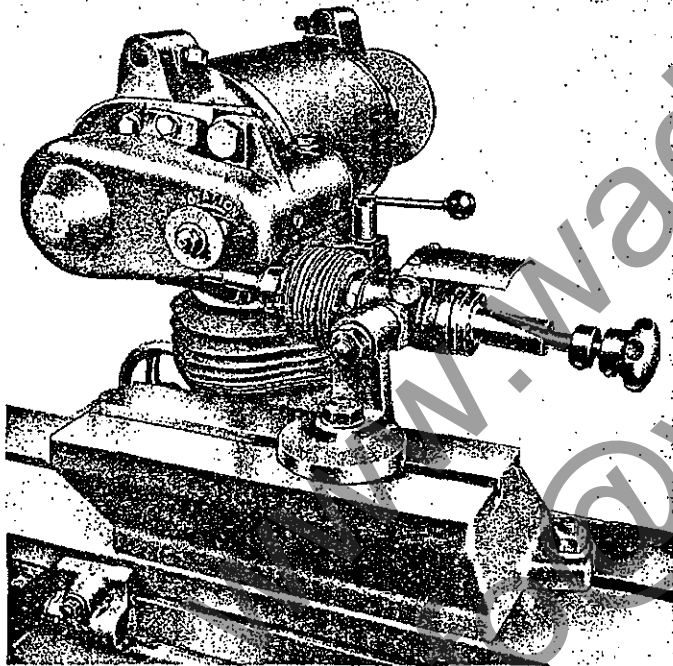

Fig. 52—Every type of cutter used on high speed routers can be ground by means of this auxiliary table and attachments. Attachment DGA shown above is for sharpening spiral and straight fluted cutters.

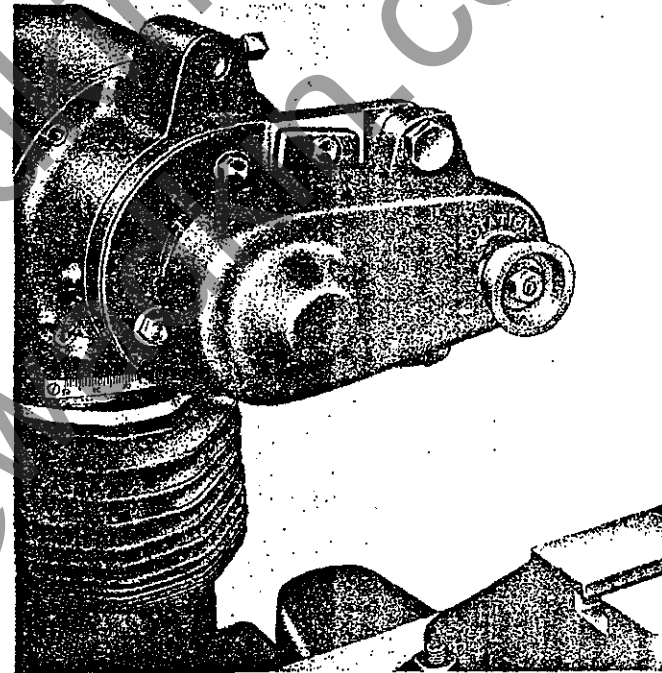

Fig. 53—High speed grinding attachment, Type NHG. It is quickly attached to the main grinding head. The spindle revolves at 5,000 r.p.m. and uses 2" and 2 $\frac{1}{4}$ " diameter grinding wheels.

WET GRINDING

We have been asked by several customers if this machine can be adapted to wet grinding.

Wet grinding is desirable on an automatic machine which is possibly left unattended for short periods and where the rate of feed is constant and the rapid traverses give rise to heating of the cutters, the purpose of the coolant being to disperse this generated heat and thus prevent the danger of the knife getting hot enough to cause cracking at the cutting edge. The liquid should flood the grinding zone, as an intermittent or scanty flow is more harmful than no flow at all.

The Wadkin Tool and Cutter Grinder has been specifically designed for dry grinding on the following considerations. Comparatively short knives are ground thus presenting a small surface area. The amount of cut is determined and controlled by the operator, thus the danger of overheating the knife is completely eliminated.

Another consideration is that the operator is watching the grinding operation continuously, and any flooding of coolant, with its necessary shrouds, splash guards and pipes would inconvenience the operator from the point of view of visual control.

A further point is that on tool and cutter grinding, after taking a cut on one knife, the block is indexed round to the next knife, thus giving intermittent grinding, whereas on the automatic machine grinding is continuous on one knife at a time, therefore the heat generated on the tool and cutter grinder is much less than that generated on the automatic machine.

INDEX

Alternative method of indexing	17, 18
Applications	15, 19, 20, 21, 22
Arbors	13, 14, 15
Bearing list	7
Canting and swivelling fixture	40, 41
Description of machine	4, 5
Detail of spindle end	8
Diamond wheels	38, 39
Dimensions and capacities	1
Dummy block	23, 24, 25
Foundation plan	6
Grinding	18
Grinding Bolinder type solid profile cutterheads	22, 23
Grinding tungsten carbide tipped cutters and saws	38
Grinding wheels	9, 10
Grinding wheel mounting	9
Grinding shear cut solid profile cutters	40, 41
Hollow grinding	25
Installation (foundations and wiring)	2, 3
Lubrication	7
Lubrication chart	6
Mounting the arbor on the dividing head	14, 15, 40
Precision dividing head	10, 11, 12
Roller setting attachment	21
Router cutter grinding attachment	26
Router cutter grinding attachment high speed	42
Setting-up for grinding	15, 16
Swivelling table attachment	28
Tenon block Adze cutter grinding attachment	29, 30, 31, 32
Tungsten carbide tipped saw grinding attachment	33, 34, 35, 36, 37
Twist drill grinding attachment	27
Wheel dressing attachment	27
Wet grinding	43

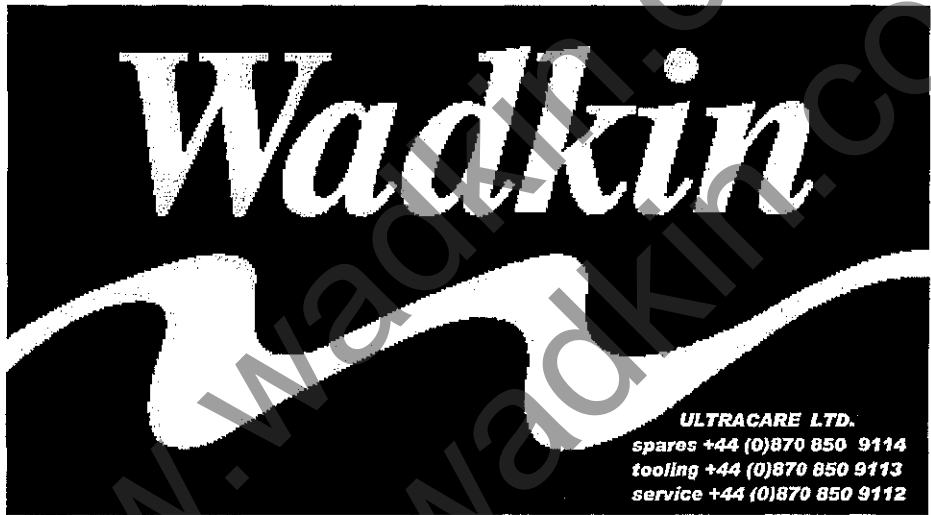

ULTRACARE LTD.

spares +44 (0)870 850 9114
tooling +44 (0)870 850 9113
service +44 (0)870 850 9112

www.wadkin.com
info@wadkin.com

WADKIN LTD

N H

UNIVERSAL CUTTER GRINDER

Operating & Maintenance Instructions

Including Parts List



SPARE PARTS BOOKLET

CONTENTS

1. Basic ordering requirements.
2. Sample type order.
3. List of item numbers and description of item.
4. Drawing showing item numbers.

12" & 24" NH

CUTTER GRINDER

SPARE PARTS

Should spare parts be required due to breakage or wear full particulars including the machine and test number must be given. This information is on the nameplate attached to the machine and will be similar to the picture below.

Wadkin Ltd. LEICESTER ENGLAND		
MACHINE SERIAL NO.	FD 6134	
MACHINE TEST NO.	70601	
PATENT NO.		
VOLTAJE	PHASE	CYCLES
400	3	50
SEE MAINTENANCE INSTRUCTION BOOK FOR LUBRICATION DETAILS		

Please see the next page for sample detail of how to order spare parts.

SAMPLE TYPE ORDER

MACHINE: NH

MACHINE NO: 1407

TEST NO: 68975

PARTS REQUIRED

1 - NH208/NH10 CUP WHEEL GUARD
1 - NH208/NH76 REAR RACK PINION SHAFT
1 - NH208/NH158 PLUNGER FOR TABLE STOP
1 - NH209/NH36 MAIN FRAME
1 - NH209/NH91 COUPLING FOR HANDWHEEL SHAFT

12" & 24" NH MACHINE SPARE PARTS LIST

NH208/NH5	FRONT BEARING HOUSING
NH208/NH10	CUP WHEEL GUARD
NH208/NH11	COVER FOR CUP WHEEL GUARD
NH208/NH14	END CAP FOR FRONT BEARING
NH208/NH21	NUT FOR TRAVERSE MOTION
NH208/NH22	BEARING FOR CROSS TRAVERSE SCREW
NH208/NH23	CROSS TRAVERSE HANDWHEEL
NH208/NH24	L.H. TABLE STOP
NH208/NH25	R.H. TABLE STOP
NH208/NH36	MAIN FRAME
NH208/NH37	CROSS TRAVERSE SLIDE
NH208/NH39	WHEELHEAD RAM
NH208/NH40	STATOR FRAME
NH208/NH41	REAR BEARING HOUSING
NH208/NH42	TABLE
NH208/NH54	REAR FLANGE FOR CUP WHEEL
NH208/NH55	BUSH FLANGE FOR CUP WHEEL
NH208/NH58	OUTER SPACING RING FOR BEARINGS
NH208/NH59	INNER SPACING RING FOR BEARINGS
NH208/NH60	GREASE RETAINER FOR REAR BEARING
NH208/NH61	SHAFT FOR CUP WHEEL GUARD
NH208/NH70	TABLE ROLLER BUSH
NH208/NH71	SLIDE ROD FOR TABLE
NH208/NH72	RACK FOR TABLE
NH208/NH75	RACK PINION
NH208/NH76	REAR RACK PINION SHAFT
NH208/NH79	BUSH FOR RACK PINION SHAFT
NH208/NH80	SLEEVE FOR MICROMETER DIAL
NH208/NH81	REAR MICROMETER DIAL
NH208/NH82	FRONT MICROMETER DIAL
NH208/NH83	TABLE ROLLER PIN

NH208/NH86	LOCK PLATE FOR CROSS TRAVERSE SLIDE
NH208/NH93	ECCENTRIC TABLE ROLLER PIN
NH208/NH119	GRINDING SPINDLE
NH208/NH125	GUARD FOR WHEELHEAD RAM
NH208/NH127	SCALE FOR ANGULAR SETTING
NH208/NH132	WIPER PLATE
NH208/NH133	WIPER FOR SLIDE RODS
NH208/NH151	LOCKNUT FOR GRINDING SPINDLE
NH208/NH152	FRONT FLANGE FOR CUP WHEEL
NH208/NH153	FRONT RACK PINION SHAFT
NH208/NH154	BUSH FOR RACK PINION SHAFT
NH208/NH155	LIP PLATE FOR CROSS TRAVERSE SLIDE
NH208/NH156	LIP PLATE FOR CROSS TRAVERSE SLIDE
NH208/NH157	STUD FOR WHEELHEAD CLAMP
NH208/NH158	PLUNGER FOR TABLE STOP
NH208/NH159	TEE BOLT FOR TABLE STOP
NH208/NH160	WHEELHEAD CLAMP (L.H.)
NH208/NH161	WHEELHEAD CLAMP (R.H.)
NH208/NH162	GREASE PIPE FOR NUT
NH208/NH164	CROSS TRAVERSE SCREW
NH208/EKA68	COLLAR FOR SPINDLE
NH208/FG1035	FISCHER BEARING
NH208/LS863	SPRING FOR SPINDLE LOCK
NH208/N4825	BALL BEARING
NH208/CA	CLAMP NUT AND LEVER
NH208/2	SPRING
NH208/2B	HANDWHEEL
NH208/2C	BALL BEARING LOCKNUT
NH208/3	GREASE RETAINER
NH208/4	HORN HANDLE

NH208/4A	STAR HANDWHEEL
NH208/4D	TWO BALL HANDLE
NH208/6D	STAR HANDWHEEL
NH209/NH9	ELEVATING GEAR BRACKET
NH209/NH15	COVER FOR MAIN FRAME
NH209/NH16	BEARING BRACKET FOR HANDWHEEL SHAFT
NH209/NH17	HANDWHEEL FOR RAISING SHAFT
NH209/NH20	SPIRAL GEAR FOR RAISING MOTION
NH209/NH36	MAIN FRAME
NH209/NH87	LOCKNUT FOR RAISING SCREW
NH209/NH88	SPIRAL PINION FOR RAISING MOTION
NH209/NH89	HANDWHEEL SHAFT FOR RAISING MOTION
NH209/NH90	SPIRAL PINION SHAFT
NH209/NH91	COUPLING FOR HANDWHEEL SHAFT
NH209/NH92	HANDWHEEL SHAFT FOR RAISING MOTION
NH209/NH130	BUSH FOR ELEVATING GEAR BRACKET
NH209/2	HORN HANDLE
NH209/LJR1 $\frac{1}{8}$	R & M ROLLER BEARING
NH209/SKF0.8.	THRUST BEARING

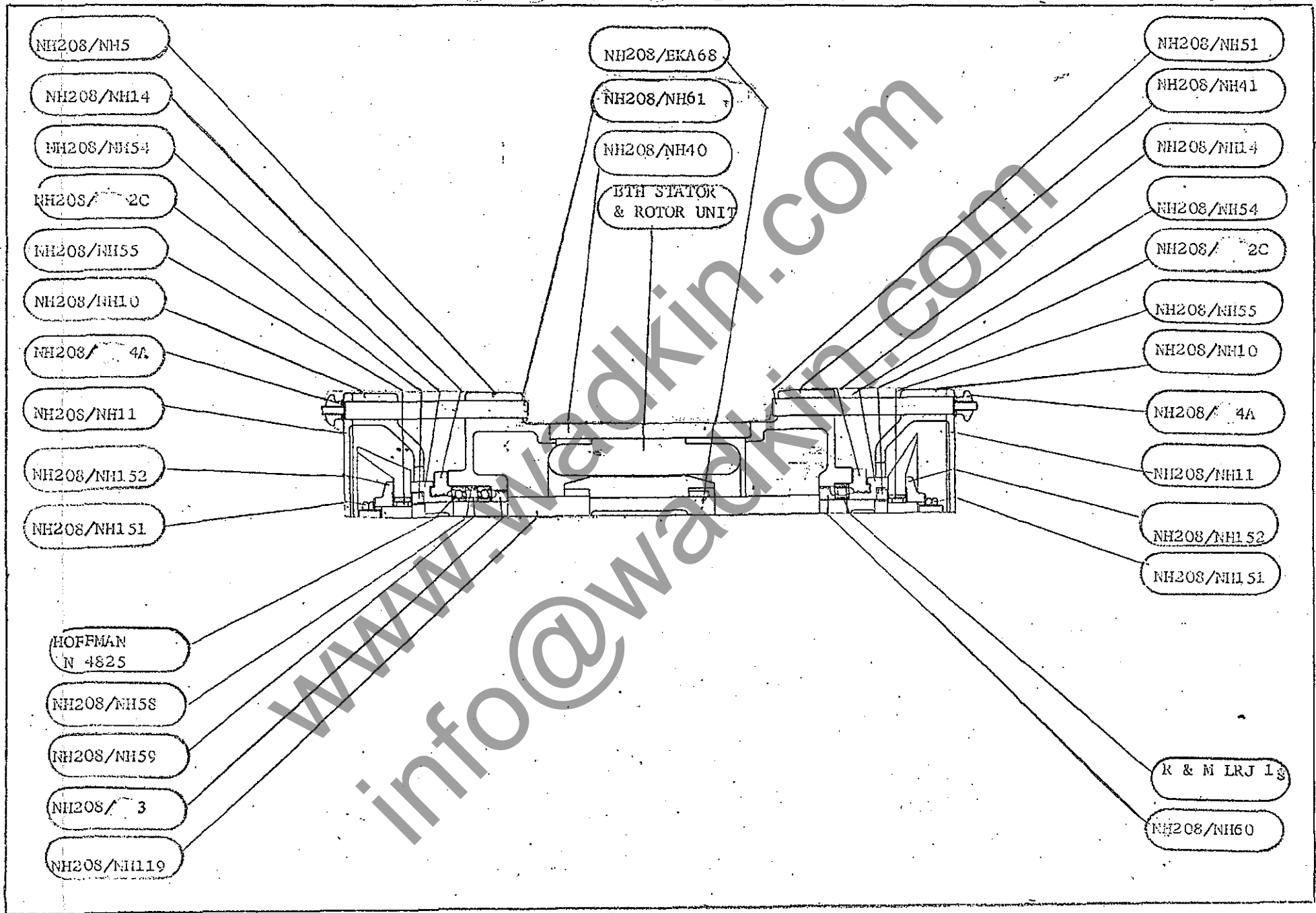

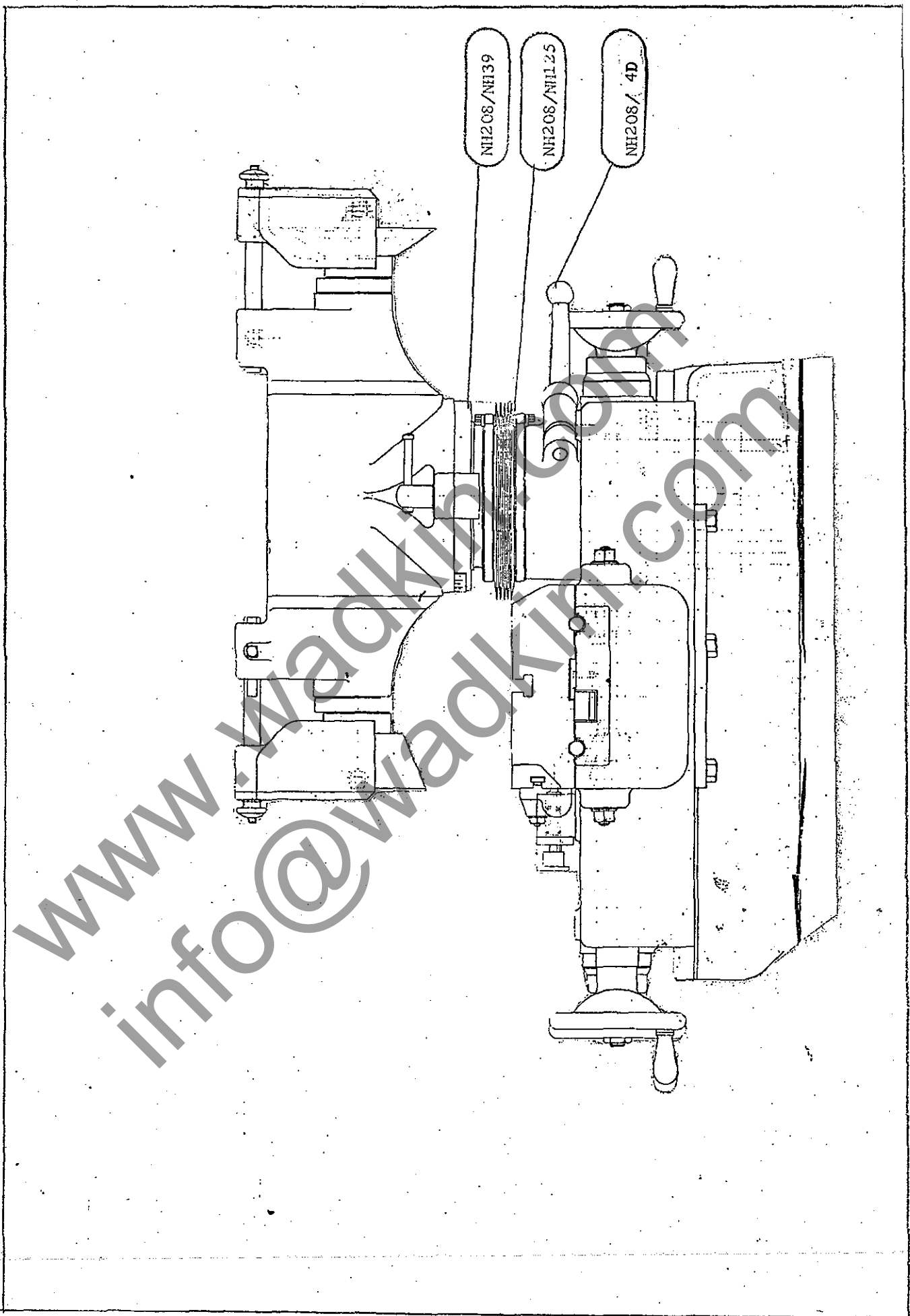

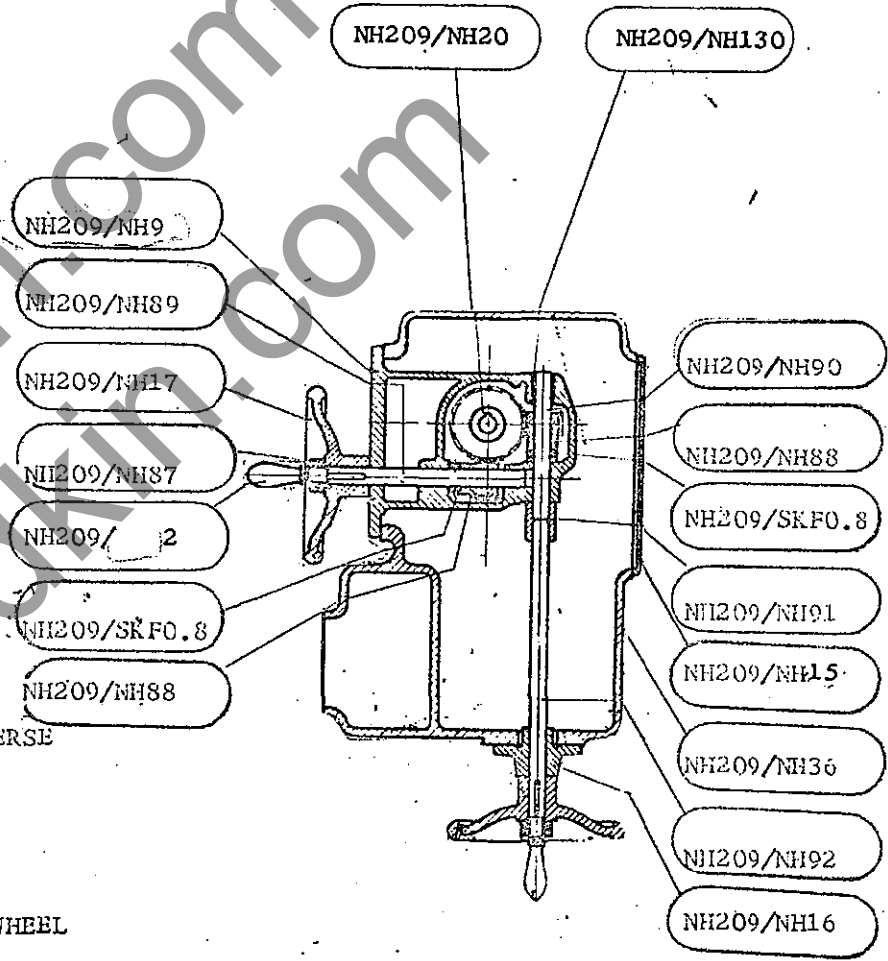
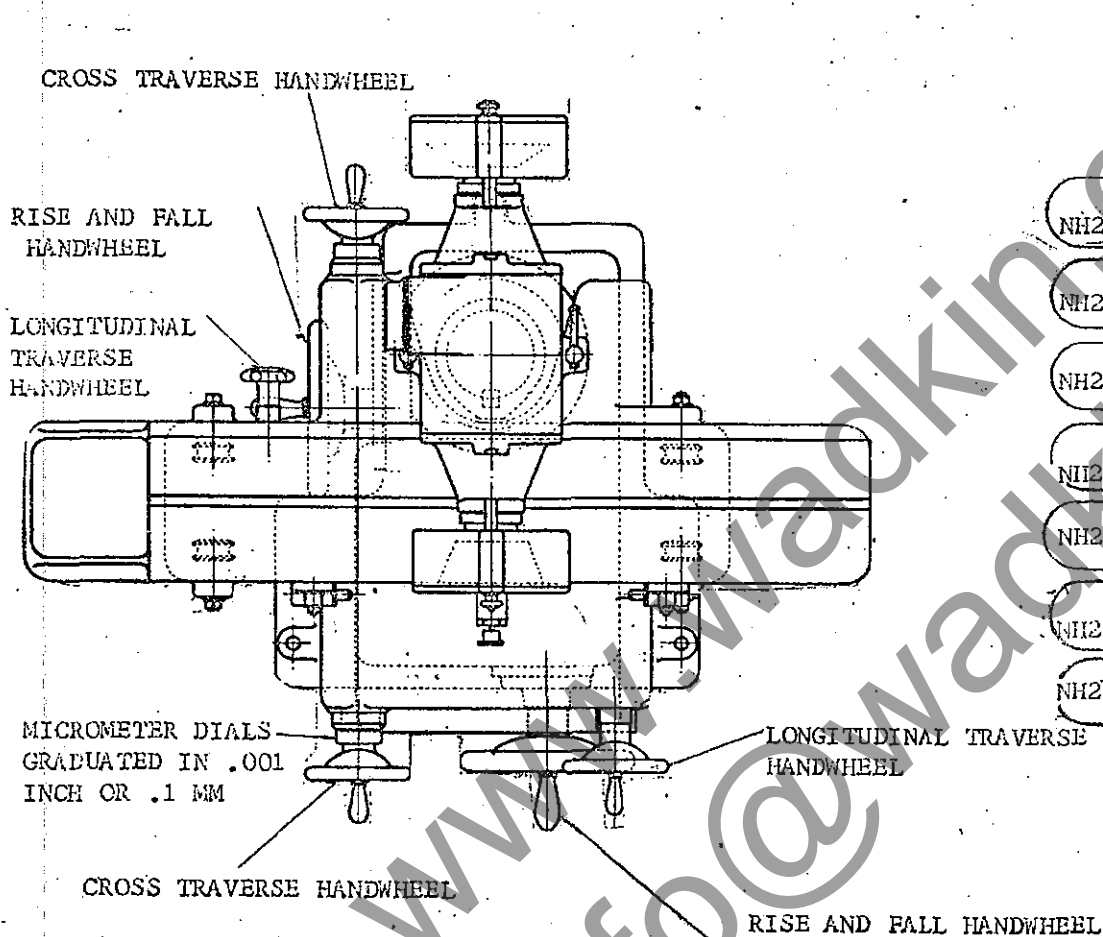

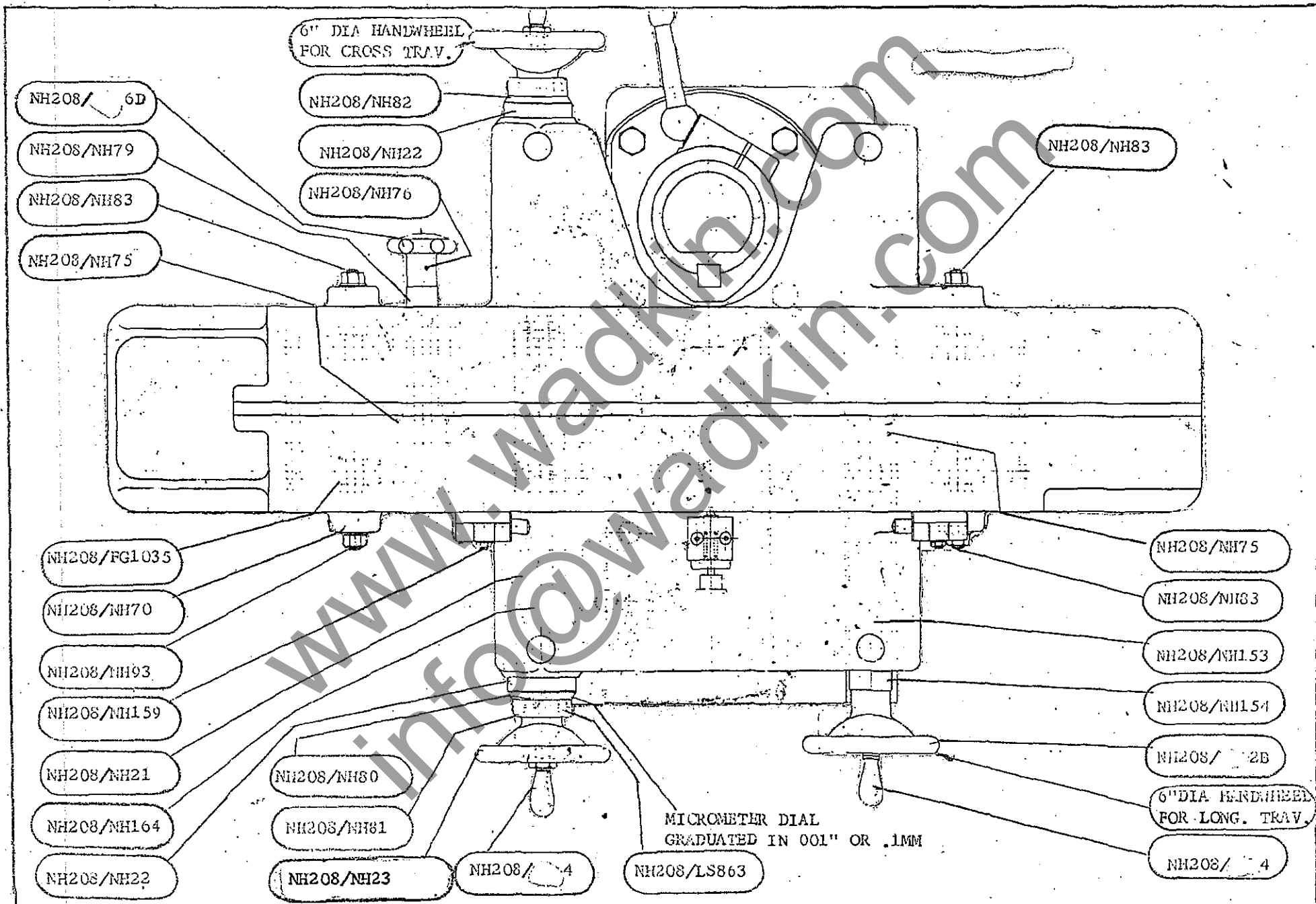

ADJUSTABLE SPRING STOPS

LOCK FOR CROSS
TRAVERSE SLIDE

LOCK FOR RISE
AND FALL MOTION

PUSH BUTTON STATION

REVERSING SWITCH

ISOLATING SWITCH
(TO SPECIAL ORDER)

12" & 24" CUTTER GRINDER NH